

### Features

- 2.4 - 2.485GHz Frequency Range
- High Efficiency Optimized for Battery Operation
- Delivers up to +10.6dBm Output Power at 3.3V
- 10.3mA at +10dBm Output Power at 3.3V
- Large Signal Gain 13.8dB at +10dBm Output Power
- 2.2 - 4.0V Operation
- Integrated PA, Bypass, T/R Switch
- -40°C to 125°C Extended Temperature Range
- 2mm x 2mm x 0.45mm 8-Pin DFN Package

### Applications

- Bluetooth Low Energy (BLE) Devices
- IoT (Internet of Things) / M2M Connectivity
- Bluetooth Audio
- Bluetooth Mesh Networks
- Sports and Medical Wearables
- Consumer Electronics, Toys
- Smart Home Appliances
- Remote Controllers Wireless Sensor Nodes
- Beacons
- Proximity Sensors

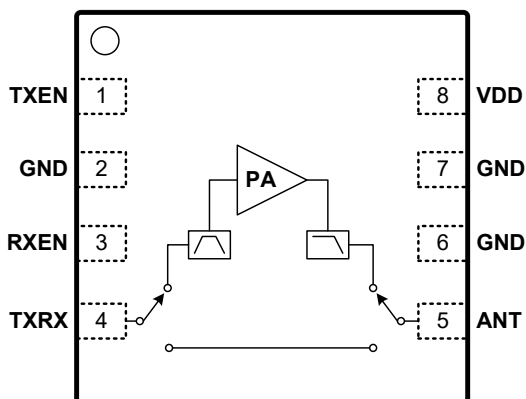

**Figure 1. 8TR1212 Functional Block Diagram**

### Description

The 8TR1212 is a compact, highly integrated front-end RFIC (Radio Frequency Integrated Circuit) intended for Bluetooth Smart, 802.15.4 ZigBee, Thread and proprietary ISM wireless protocol systems in the 2.4GHz band.

The 8TR1212 is optimized for battery operation with enhanced efficiency, operating over a wide voltage supply range from 2.2V to 4.0V, suited for a wide array of applications including battery-powered wireless systems.

The 8TR1212 combines a transmit power amplifier (PA), Bypass, a single pole, double throw (SPDT) transmit / receive (T/R) switch (Figure 1) in a 2mm x 2mm x 0.45mm 8-pin DFN package. It also comes integrated with filter networks and input / output matching circuitry. The device delivers up to +10.6dBm saturated output power at a supply voltage of 3.3V.

The 8TR1212 is RoHS compliant, halogen-free and REACH Compliant. It is rated for Moisture Sensitivity Level 1 (MSL1), reflow at 260°C per JEDEC J-STD-020. Refer to IPC / JEDEC J-STD-020 for detailed solder reflow temperature and profile.

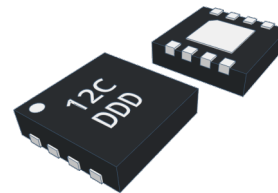

8-pin 2mm x 2mm x 0.45mm, DFN Package

**Figure 2. 8TR1212 Package Type**

### Ordering Information

Part Number	Product Description
8TR1212	2.4GHz Front-End RFIC 2500pieces per Tape and Reel
8TR1212-EVB	Fully Tested and Characterize Evaluation Board
8TR1212-DWF	2.4GHz Front-End RFIC Die in Wafer Form

## Pin Descriptions

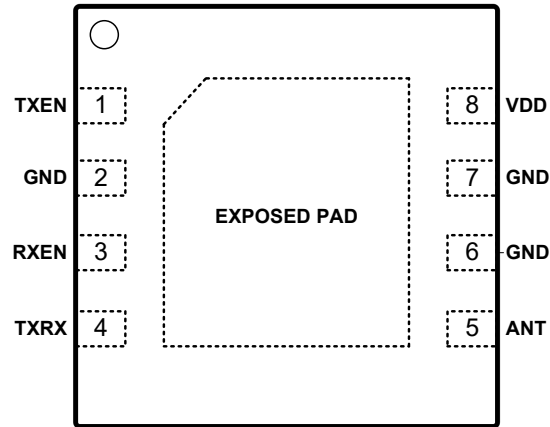

**Figure 3. 8TR1212 Pinout (Top View)**

**Table 1. 8TR1212 Signal Descriptions**

Pin	Name	Description
1	TXEN	Control Logic Pin
2	GND	Ground
3	RXEN	Control Logic Pin
4	TXRX	Transmit/Receive Port (DC shorted to GND)
5	ANT	Antenna Port (DC shorted to GND)
6	GND	Ground
7	GND	Ground
8	VDD	DC Voltage Supply
EXPOSED PAD		Exposed pad should be connected to GND.

### Electrical and Mechanical Specifications

The absolute maximum ratings of the 8TR1212 are provided in Table 2. The recommended operating conditions are specified in Table 3.

The electrical specifications are provided in Tables 4 through 6, as measured on 8TR1212 evaluation board(Figure 4).

The state of the 8TR1212 is determined by the logic provided in Table 7.

**Table 2. 8TR1212 Absolute Maximum Ratings**

Parameter		Units	Minimum	Maximum	Remark
Supply Voltage (VDD)		V	0	4.4	
Control Logic Pin (TXEN, RXEN)		V	0	VDD	
Transmit Input Power at TXRX Port		dBm		10	
Bypass Input power at ANT Port		dBm		20	
Storage Temperature		°C	-40	150	
ESD - HBM*	All pins	V		±3000	

Note: Sustained operation at or above the Absolute Maximum Ratings for any single or combinations of the parameters above may result in permanent damage to the device and is not recommended. All Maximum RF Input Power Ratings assume 50Ω terminal impedance.

\*Electrostatic discharge Human Body Model(HBM) Reference Document: ANSI/ESDA/JEDEC JS-001-2017

**Table 3. 8TR1212 Recommended Operating Conditions**

Parameter	Units	Min	Typ	Max
Supply Voltage (VDD, recommended)*	V	2.2	3.3	4
Control Pin - Logic High State (TXEN, RXEN)	V	1.5		VDD**
Control Pin - Logic Low State (TXEN, RXEN)	V	0		0.5
Operating Frequency Range	GHz	2.4		2.485
Operating Temperature	°C	-40	25	125

\* Functional working with degraded performance for the supply voltage range 2.2V to 2.7V.

\*\* For Control Voltages > 3.0V, a 10kΩ series resistor should be used at the Control Logic Pins.

**Table 4. 8TR1212 Electrical Specifications: Transmit Mode**

 (VDD = 3.3V, TXEN = High, RXEN = Low or High, T<sub>Ambient</sub> = 25°C, Excluding PCB and Connector Loss, Unless Otherwise Noted)

Parameter	Units	Min	Typ	Max	Test Condition
Saturated Output Power	dBm		9.8 10.6 12.1		VDD 3.0V VDD 3.3V VDD 4.0V
Large-Signal Gain	dB		13.8		+10dBm Pout
Current Consumption	mA		10.3		+10dBm Pout
Tx Quiescent Current	mA		2.57		No RF applied
Second Harmonic	dBm/MHz		-28.1		+10dBm Pout Without external harmonic filter
Third Harmonic	dBm/MHz		-40.8		
Input Return Loss	dB		20		At TXRX port
Output Return Loss	dB		13		At ANT port
Load VSWR for Stability			6:1		All Non-harmonic Spurs Less than -55dBm/MHz Up to +10dBm
Load VSWR for Ruggedness			10:1		No Damage

**Table 5. 8TR1212 Electrical Specifications: Bypass Mode**

 (VDD = 3.3V, TXEN = Low, RXEN = High, T<sub>Ambient</sub> = 25°C, Excluding PCB and Connector Loss, Unless Otherwise Noted)

Parameter	Units	Min	Typ	Max	Test Condition
Bypass Current	uA		1		
Insertion Loss	dB		1.4		

**Table 6. 8TR1212 Electrical Specifications: Switching Time**

 (VDD = 3.3V, T<sub>Ambient</sub> = 25°C, Unless Otherwise Noted)

Parameter	Units	Min	Typ	Max	Test Conditions
TX to Bypass	nsec		300		From 50% of TXEN to 90% of Bypass power
TX to Shutdown	nsec		300		From 50% of TXEN to 10% of TX power
Bypass to TX	nsec		600		From 50% of TXEN to 90% of TX power
Bypass to Shutdown	nsec		300		From 50% of RXEN to 10% of Bypass power
Shutdown to TX	nsec		600		From 50% of TXEN to 90% of TX power
Shutdown to Bypass	nsec		300		From 50% of RXEN to 90% of Bypass power

**Table 7. 8TR1212 Electrical Specifications: Mode Control Logic**

("1" = Logic High, "0" = Logic Low, All Control logic pins must have a state defined as either "0" or "1".)

TXEN	RXEN	Operational Mode
0	0	Shutdown Mode
0	1	Bypass Mode
1	0 or 1	Transmit Mode

### Application Notes

The 8TR1212 Application note provides detailed descriptions and test data over various operating conditions. Visit [www.berex.com](http://www.berex.com) or contact BeRex at [sales@berex.com](mailto:sales@berex.com) to request additional documentation.

### Evaluation Board Schematic and PCB Layout

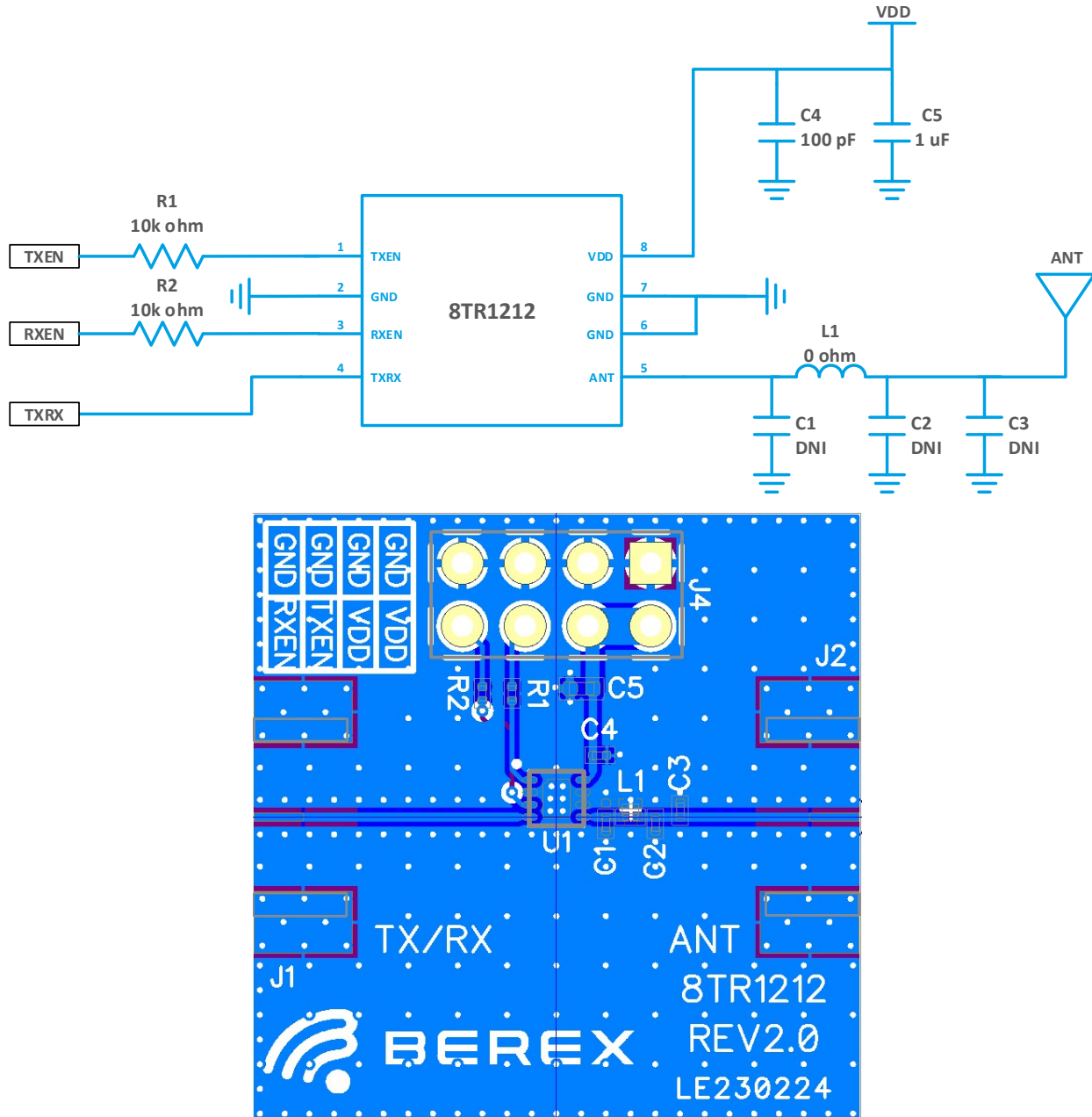
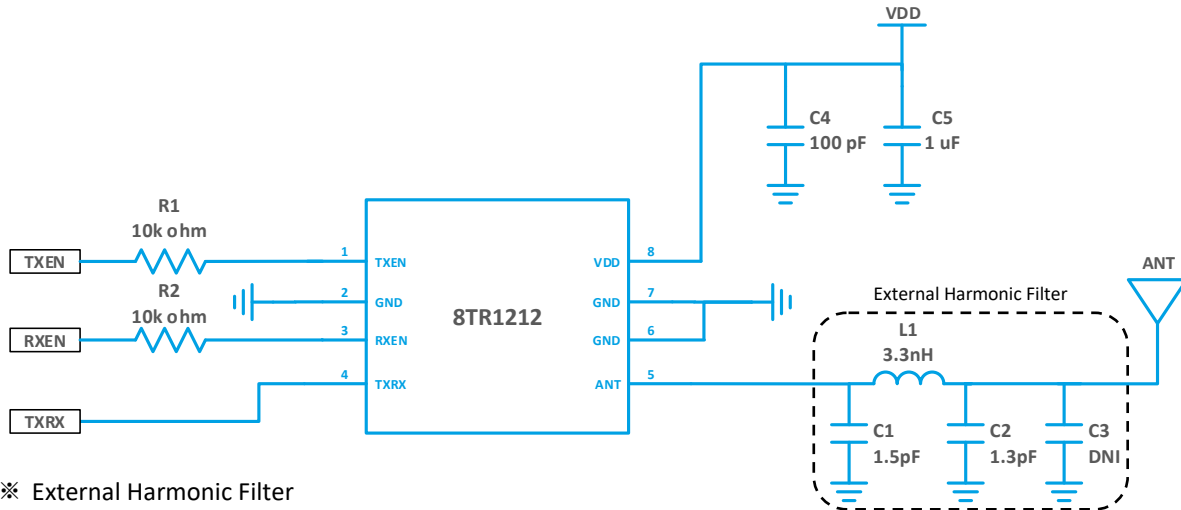

Figure 4. 8TR1212 Evaluation Board Schematic and PCB Layout

**Table 8. 8TR1212 Evaluation Board Bill of Materials (BOM)**

Component	Value	Manufacturer	Mfr Part Number	Size	Description
R1, R2	10 kΩ	YAGEO	RC0201JR-7D10KL	0201	Thick Film Resistors 10 kΩ 50mW 0201 5%
C1, C2, C3	DNI			0201	
C4	100 pF	muRata	GRM0335C1E101JA01J	0201	Cap ceramic 100 pF 25V COG/NP0 0201 5%
C5	1 uF	muRata	GRM155R61C105KA12D	0402	Cap ceramic 1 uF 16V X5R 0402 10%
L1	0 Ω	YAGEO	RC0201JR-070RL	0201	Thick Film Resistors 0 Ω 50mW 0201 5%
J1, J2	SMA	Gigalane	PAF-S05-008	End launch	SMA 50 Ohm End Launch Jack Receptacle
J4	10x2	Adam Tech	PH2RA-08-UA	2x4	HEADER DR RA TH 2X4
U1	8TR1212	BeRex	8TR1212	DFN 2x2	2.4GHz ZigBee/Thread/Bluetooth Smart Front End RFIC

### Application Schematic



※ External Harmonic Filter

Performance is sensitive to PCB parasitics. Therefore, custom PCB layout should emulate the Evaluation Board PCB layout attached to this design as closely as possible.

All inductors and capacitors must be populated and located as close as possible to ANT pin. Use ceramic multi-layer inductors for effective filtering.

Depending on layout, all inductor and capacitor values may require minor value tweaks for optimum impedance matching.

**Figure 5. 8TR1212 Application Schematic**

**Table 9. 8TR1212 Application Bill of Materials (BOM)**

Component	Value	Manufacturer	Mfr Part Number	Size	Description
R1, R2	10 kΩ	YAGEO	RC0201JR-7D10KL	0201	Thick Film Resistors 10 kΩ 50mW 0201 5%
C1	1.5 pF	muRata	GRM0335C1E1R5WA01D	0201	Cap ceramic 1.5 pF 25V C0G/NP0 0201 +/-0.05pF
C2	1.3 pF	muRata	GRM0335C1E1R3WA01D	0201	Cap ceramic 1.3 pF 25V C0G/NP0 0201 +/-0.05pF
C3	DNI			0201	
C4	100 pF	muRata	GRM0335C1E101JA01J	0201	Cap ceramic 100 pF 25V C0G/NP0 0201 5%
C5	1 uF	muRata	GRM155R61C105KA12D	0402	Cap ceramic 1 uF 16V X5R 0402 10%
L1	3.3 nH	muRata	LQP03TN3N3B02D	0201	Fixed ind 3.3 nH 450mA 250mΩ +/-0.1nH
J1, J2	SMA	Gigalane	PAF-S05-008	End launch	SMA 50 Ohm End Launch Jack Receptacle
J4	10x2	Adam Tech	PH2RA-08-UA	2x4	HEADER DR RA TH 2X4
U1	8TR1212	BeRex	8TR1212	DFN 2x2	2.4GHz ZigBee/Thread/Bluetooth Smart Front End RFIC

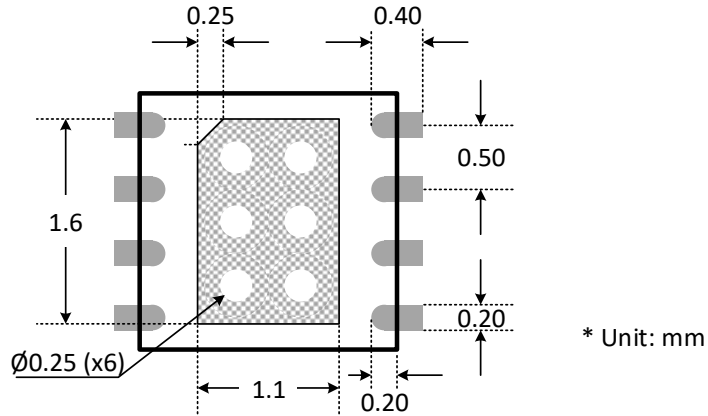
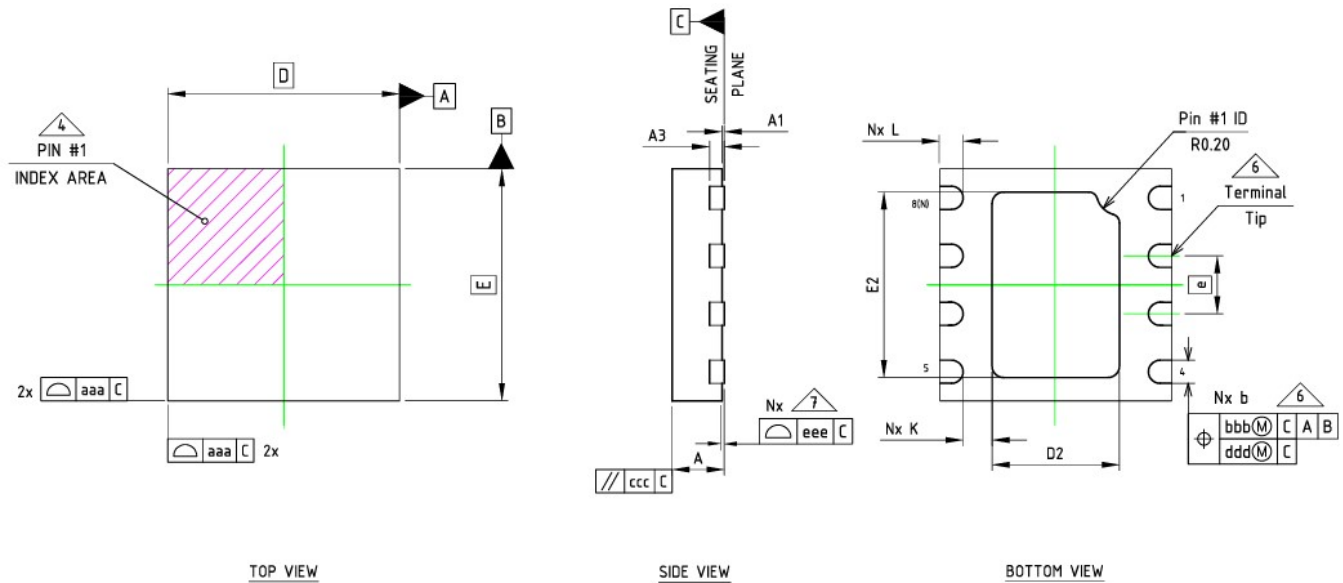

**Package Dimensions**

**Figure 6. 8TR1212 PCB Layout Footprint**

	MINIMUM	NOMINAL	MAXIMUM		MINIMUM	NOMINAL	MAXIMUM
A	0.41	0.45	0.50	K	0.20	---	---
A1	0.00	0.02	0.05	L	0.10	0.20	0.30
A3	---	0.127 Ref	---	aaa	0.05		
b	0.15	0.20	0.25	bbb	0.10		
D	2.00 BSC			ccc	0.10		
E	2.00 BSC			ddd	0.05		
e	0.50 BSC			eee	0.08		
D2	1.00	1.10	1.20	N	8		
E2	1.50	1.60	1.70	NE	4		

**Figure 7. 8TR1212 Package Dimensions**

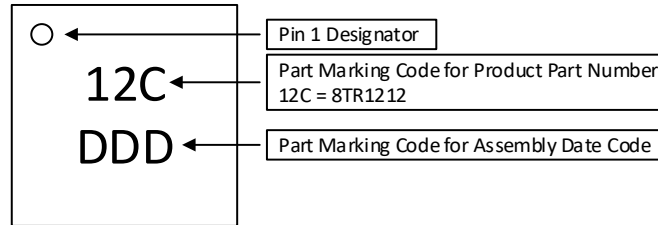
### Package Marking



Note: The part marking: 12C represents the Product Part Number: 8TR1212.

Due to the size limitations of this package, only three (3) characters can be marked on each of two (2) rows. Therefore the Product Part Number is represented in the part marking by a 3-character code.

**Figure 8. 8TR1212 Typical Part Markings**

### ESD Handling Information

Electro Static Discharge (ESD) can cause immediate (or latent) failures in semiconductor Integrated Circuits (ICs). BeRex, Inc. RFIC products are designed with integral ESD protection structures, and all IC products are tested to meet industry standards for ESD event survival. Users must adhere to all precautions for handling ESD sensitive devices throughout the manufacturing, test, shipping, handling, or operational processes, and during field service operations in order to achieve optimum system performance and life expectancy. Production quantities of this product are shipped in a standard tape and reel format.

### RoHS Compliance

This part is compliant with Restrictions on the Use of Certain Hazardous Substances in Electrical and Electronic Equipment (RoHS) Directive 2011/65/EU as amended by Directive 2015/863/EU.

This part is lead-free, halogen-free and compliant with a concentration of the Substances of Very High Concern (SVHC) candidate list which are contained in a quantity of less than 0.1%(w/w) in each component of a product and/or its packaging placed on the European Community market by the BeRex and Suppliers.

### Tape & Reel

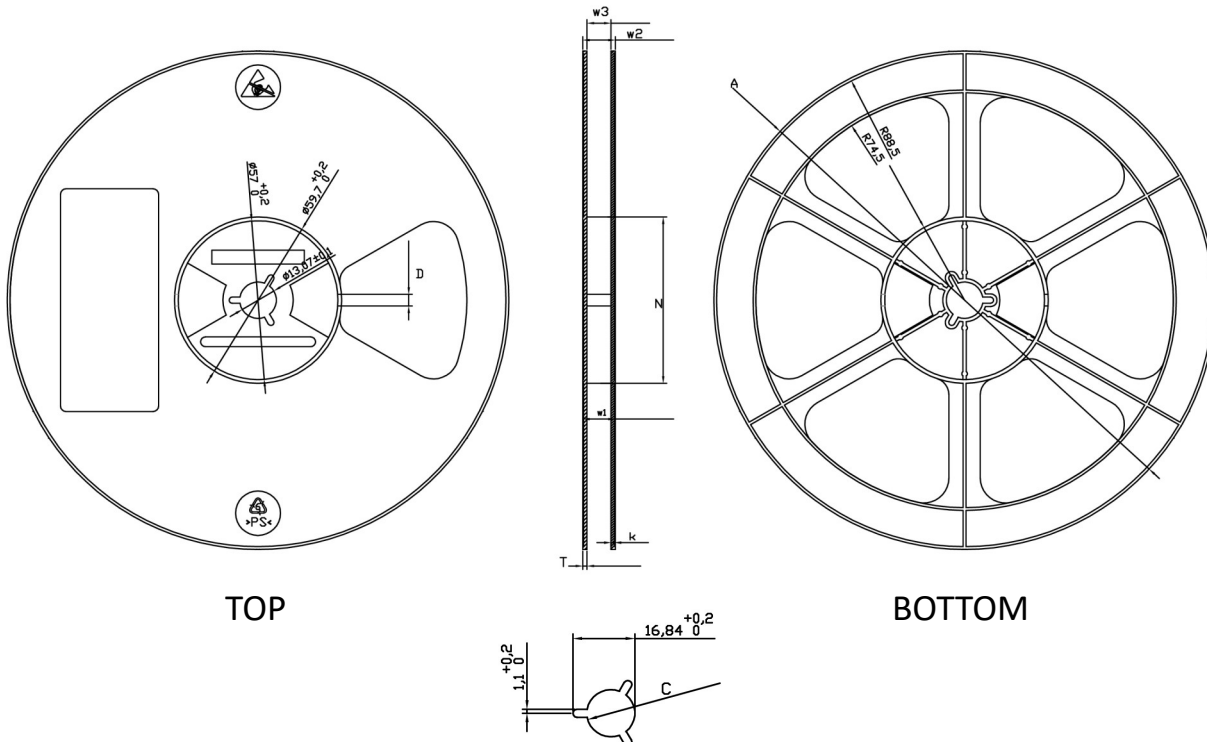

TYPE	A	N	C	D	w1	w2	w3	T	k
8MM	+2 $\phi 180 - 2$	+1 $\phi 60 - 1$	+0,2 $\phi 13,1 - 0,2$	$4,2 \pm 0,5$	+1 $8,4 - 0$	+1 $11,6 - 1$	+1 $8,75 - 1$	$1,5 \pm 0,15$	+0,1 $1,25 - 0,05$

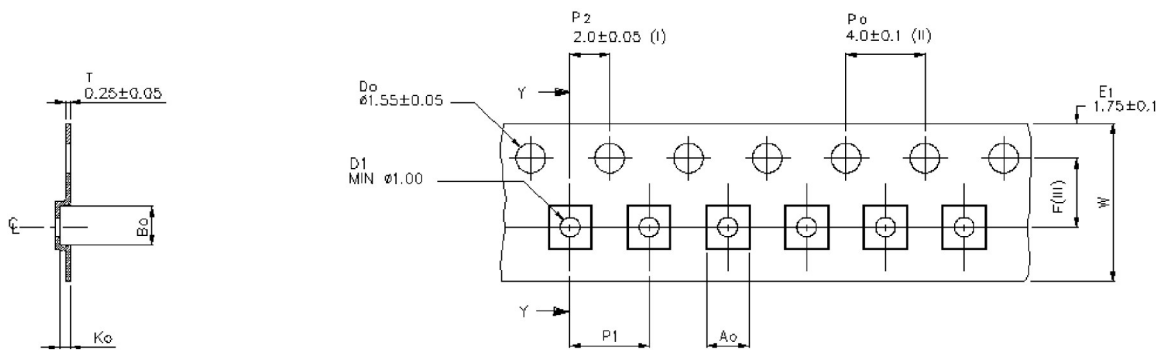

SECTION Y-Y

$A_0$	$2.20 \pm 0.05$
$B_0$	$2.20 \pm 0.05$
$K_0$	$0.55 \pm 0.05$
$F$	$3.50 \pm 0.05$
$P1$	$4.00 \pm 0.10$
$W$	$8.00 \pm 0.3 / -0.1$

- (I) Measured from centreline of sprocket hole to centreline to pocket.
- (II) Cumulative tolerance of 10 sprocket holes is  $\pm 0.20$ .
- (III) Other material available.

ALL DIMENSIONS IN MILLIMETRES UNLESS OTHERWISE STATED

Figure 9. 8TR1212 Tape and Reel Dimensions