

Features

- 2.4 - 2.485GHz Frequency Range
- High Efficiency Optimized for Battery Operation
- Delivers up to +23dBm Output Power at 3.3V
- 160mA at +23dBm Output Power at 3.3V
- 1.9dB RX LNA Noise Figure
- 2.7 - 4.0V Operation
- Single-Ended Transceiver Interface
- -40°C to 125°C Extended Temperature Range
- 3mm x 3mm x 0.45mm 16-Pin QFN Package

Applications

- Bluetooth Low Energy (BLE) Mesh Networks
- 802.15.4 ZigBee, RF4CE, Proprietary ISM
- Thread, Matter
- IoT (Internet of Things) / M2M Connectivity
- Smart Home Hubs and Gateways
- Consumer Electronics, Smart Appliances
- Smart Lighting, Smart Metering
- Drone, Toy, Media Remote Controller
- Industrial Wireless Sensor Networks
- Home, Industrial, Factory Automation
- Wireless Sensor Nodes & Networks
- Wireless Audio & Video

Description

The 8TR8219 is a compact, multi-function Front-End RFIC (Radio Frequency Integrated Circuit) intended for 802.15.4 ZigBee, Thread, Matter, Bluetooth Smart and proprietary ISM wireless protocol systems in the 2.4GHz band.

The 8TR8219 is optimized for battery operation with enhanced efficiency, operating over a wide voltage supply range from 2.7V to 4.0V, suited for a wide array of applications including battery-powered wireless systems.

The 8TR8219 combines a transmit power amplifier (PA), receive low noise amplifier (LNA), a single pole, double throw (SPDT) transmit / receive (T/R) switch (Figure 1) in a 3mm x 3mm x 0.45mm 16-pin QFN package. It also comes integrated with filter networks and input / output matching circuitry. The device delivers up to +23dBm saturated output power at a supply voltage of 3.3V.

The 8TR8219 is RoHS compliant, halogen-free and REACH Compliant. It is rated for Moisture Sensitivity Level 1 (MSL1), reflow at 260°C per JEDEC J-STD-020. Refer to IPC / JEDEC J-STD-020 for detailed solder reflow temperature and profile.

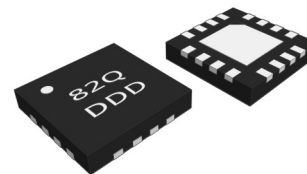

16-Lead 3mm x 3mm x 0.45mm, QFN Package

Figure 2. 8TR8219 Package Type

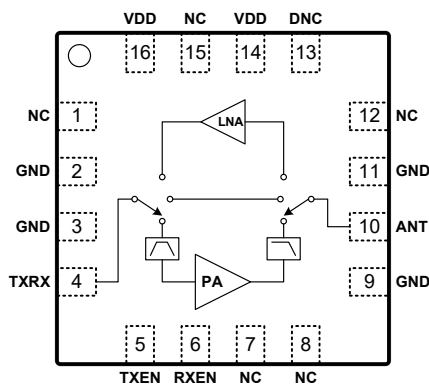
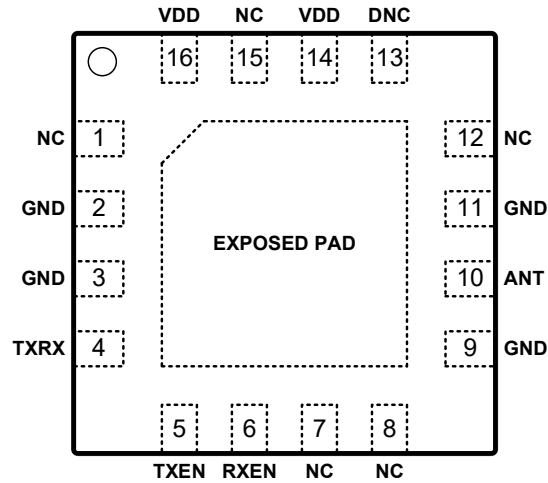

Figure 1. 8TR8219 Functional Block Diagram

Ordering Information

Part Number	Description
8TR8219	2.4GHz Front-End RFIC 2500pieces per Tape and Reel
8TR8219-EVB	Fully Tested and Characterize Evaluation Board
8TR8219-DWF	2.4GHz Front-End RFIC Die in Wafer Form

Pin Descriptions

Figure 3. 8TR8219 Pinout (Top View)
Table 1. 8TR8219 Signal Descriptions

Pin	Name	Description	Pin	Name	Description
1	NC	Not connected internally	9	GND	Ground
2	GND	Ground	10	ANT	Antenna Port (DC shorted to GND)
3	GND	Ground	11	GND	Ground
4	TXRX	Transmit/Receive Port (DC shorted to GND)	12	NC	Not connected internally
5	TXEN	Control Logic Pin	13	DNC	Do Not connect
6	RXEN	Control Logic Pin	14	VDD	Alternate DC Voltage supply pin (Internally connected to pin 16)
7	NC	Not connected internally	15	NC	Not connected internally
8	NC	Not connected internally	16	VDD	DC Voltage Supply
EXPOSED PAD		Exposed pad should be connected to GND.			

Electrical and Mechanical Specifications

The absolute maximum ratings of the 8TR8219 are provided in Table 2. The recommended operating conditions are specified in Table 3.

The electrical specifications are provided in Tables 4 through 7, as measured on 8TR8219 evaluation board(Figure 4).

The state of the 8TR8219 is determined by the logic provided in Table 8.

Table 2. 8TR8219 Absolute Maximum Ratings

Parameter		Units	Minimum	Maximum	Remark
Supply Voltage (VDD)		V	0	4.4	
Control Logic Pin (TXEN, RXEN)		V	0	VDD	
Transmit Output Power at ANT Port		dBm		24.5	
Transmit Input Power at TXRX Port		dBm		10	
Receive Input power at ANT Port		dBm		15	
Bypass Input power at ANT Port		dBm		20	
Storage Temperature		°C	-40	150	
ESD - HBM*	VDD (Pin 14, 16)	V		±500	
	All other pins	V		±3000	
ESD - HBM with application circuits*	All pins	V		±4000	VDD to GND: with shunt TVS Diode and 1uF capacitor**

Note: Sustained operation at or above the Absolute Maximum Ratings for any single or combinations of the parameters above may result in permanent damage to the device and is not recommended. All Maximum RF Input Power Ratings assume 50Ω terminal impedance.

*Electrostatic discharge Human Body Model(HBM) Reference Document: ANSI/ESDA/JEDEC JS-001-2017

**For more details, see the application note AN230807v1.8

Table 3. 8TR8219 Recommended Operating Conditions

Parameter	Units	Minimum	Typical	Maximum
Supply Voltage (VDD, recommended)	V	2.7	3.3	4
Supply Voltage (VDD, extend supply voltage)**	V	2.2		4
Control Pin - Logic High State (TXEN, RXEN)	V	1.2		VDD*
Control Pin - Logic Low State (TXEN, RXEN)	V	0		0.4
Operating Frequency Range	GHz	2.4		2.485
Operating Temperature	°C	-40	25	125

*For Control Voltages > 3.0V, a 10kΩ series resistor should be used at the Control Logic Pins.

**Functional working with degraded performance for the supply voltage range 2.2V to 2.7V.

Table 4. 8TR8219 Electrical Specifications: Transmit Mode

 (VDD = 3.3V, TXEN = High, RXEN = Low or High, T_{Ambient} = 25°C, Excluding PCB and Connector Loss, Unless Otherwise Noted)

Parameter	Units	Min	Typ	Max	Test Conditions
Saturated Output Power	dBm		23		
Large-Signal Gain	dB		24		+23dBm Pout
Current Consumption	mA		95		+20dBm Pout
			160		+23dBm Pout
Tx Quiescent Current	mA		20		No RF applied
Second Harmonic	dBm/MHz		-10		+22dBm Pout IEEE 802.15.4 OQPSK signal
Third Harmonic	dBm/MHz		-15		
Input Return Loss	dB		15		
Output Return Loss	dB		10		
Load VSWR for Stability			6:1		All Non-harmonic Spurs Less than -43dBm/MHz Up to +23dBm
Load VSWR for Ruggedness			10:1		No Damage

Table 5. 8TR8219 Electrical Specifications: Receive Mode

 (VDD = 3.3V, TXEN = Low, RXEN = High, T_{Ambient} = 25°C, Excluding PCB and Connector Loss, Unless Otherwise Noted)

Parameter	Units	Min	Typ	Max	Test Conditions
Small-Signal Gain	dB		16.5		
Current Consumption	mA		5.5		
Noise Figure	dB		1.9		
Input P1dB	dBm		-11		
Input IP3	dBm		-2		Pin = -35dBm/Tone, 1MHz spacing
Input Return Loss	dB		7		
Output Return Loss	dB		10		

Table 6. 8TR8219 Electrical Specifications: Bypass Mode

 (VDD = 3.3V, TXEN = Low, RXEN = Low, T_{Ambient} = 25°C, Excluding PCB and Connector Loss, Unless Otherwise Noted)

Parameter	Units	Min	Typ	Max	Test Conditions
Bypass Current	uA		3.5		
Insertion Loss	dB		1.7		

Table 7. 8TR8219 Electrical Specifications: Switching Time

 (VDD = 3.3V, T_{Ambient} = 25°C, Unless Otherwise Noted)

Parameter	Units	Min	Typ	Max	Test Conditions
TX to RX	nsec		800		From 50% of TXEN to 90% of RX power
TX to Bypass	nsec		250		From 50% of TXEN to 90% of Bypass power
RX to TX	nsec		850		From 50% of TXEN to 90% of TX power
RX to Bypass	nsec		250		From 50% of RXEN to 90% of Bypass power
Bypass to TX	nsec		850		From 50% of TXEN to 90% of TX power
Bypass to RX	nsec		800		From 50% of RXEN to 90% of RX power

Table 8. 8TR8219 Electrical Specifications: Mode Control Logic

"1" = Logic High, "0" = Logic Low, All Control logic pins must have a state defined as either "0" or "1".

TXEN	RXEN	Operational Mode
0	0	Bypass Mode
0	1	RX Mode
1	0 or 1	TX Mode

Application Notes

The 8TR8219 Application note provides detailed descriptions and test data over various operating conditions. Visit www.berex.com or contact BeRex at sales@berex.com to request additional documentation.

Evaluation Board Schematic and PCB Layout

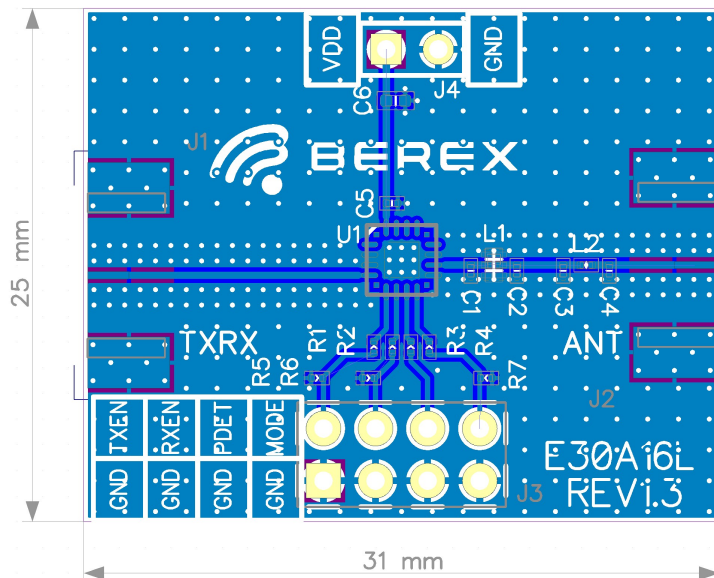
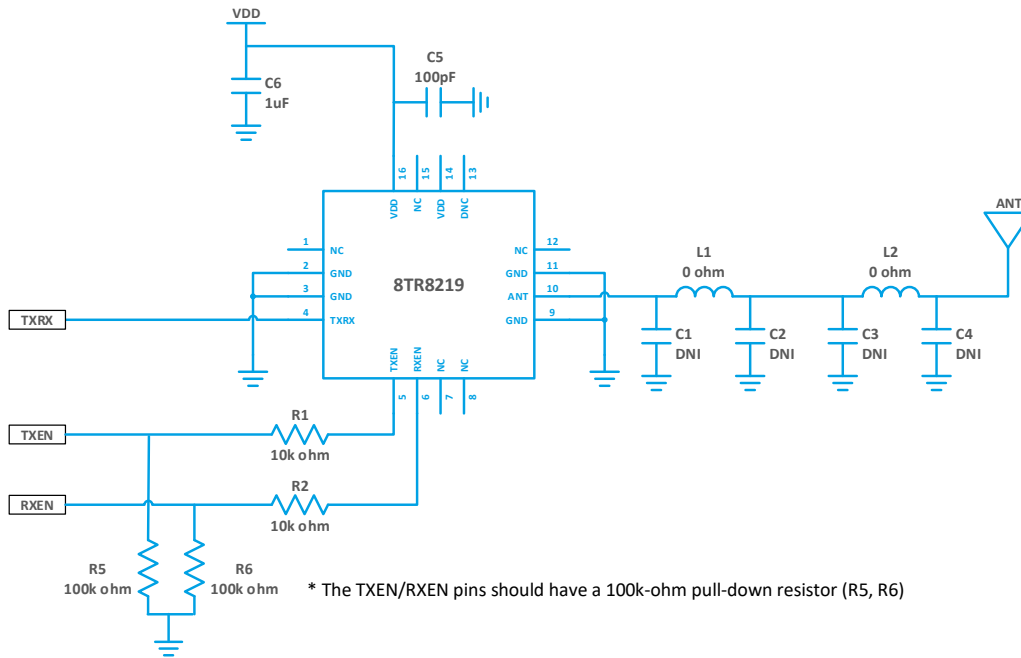
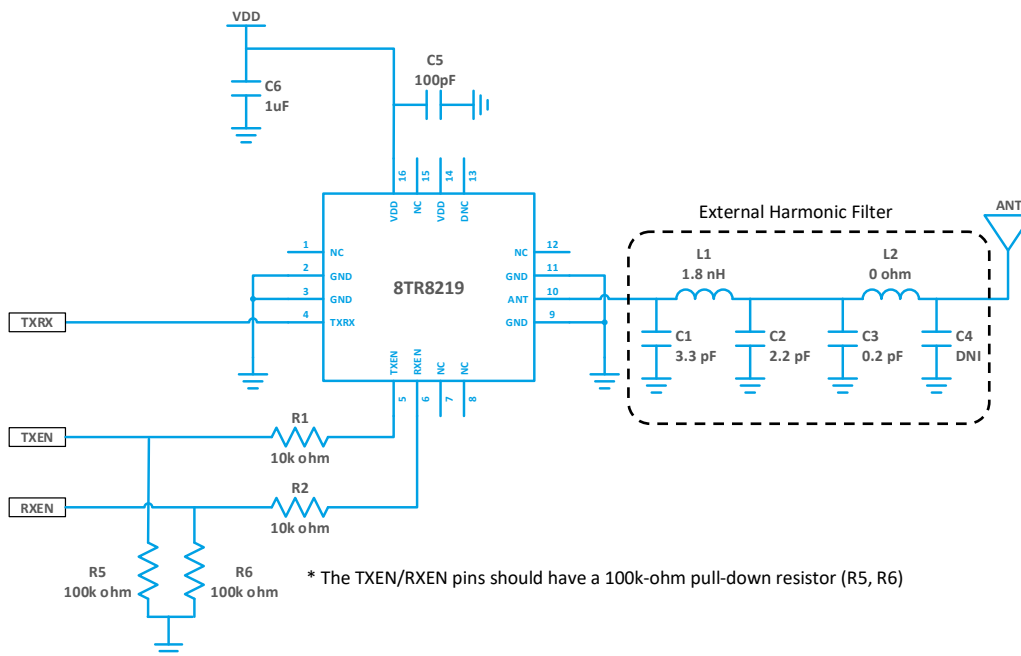

Figure 4. 8TR8219 Evaluation Board Schematic and PCB Layout

Table 9. 8TR8219 Evaluation Board Bill of Materials (BOM)

Component	Value	Manufacturer	Mfr Part Number	Size	Description
R1, R2	10 kΩ	Panasonic	ERJ-1GNF1002C	0201	RES SMD 10K OHM 1% 1/20W 0201
R5, R6	100 kΩ	Panasonic	ERJ-1GNF1003C	0201	Thick Film Resistors 100 kΩ 50mW 0201
C5	100 pF	muRata	GRM0335C1H101JA01D	0201	CAP CER 100PF 50V COG/NPO 0201
C6	1 uF	muRata	GRM155Z71A105KE01J	0402	CAP CER 1UF 10V X7R 0402
L1, L2	0 Ω	Panasonic	ERJ-1GN0R00C	0201	RES SMD 0 OHM JUMPER 1/20W 0201
J1, J2	SMA	Gigalane	PAF-S05-008	End launch	SMA 50 Ohm End Launch Jack Receptacle
J3, J4	10x2	Adam Tech	PH2RA-08-UA	2x4/2x1	HEADER DR RA TH 2X4/ 2x1
U1	8TR8219	BeRex	8TR8219	QFN 3x3	2.4GHz ZigBee/Thread/Bluetooth Smart FEM
C1 ~ C4, R3, R4	DNI			0201	

Application Schematic



⊗ External Harmonic Filter

Performance is sensitive to PCB parasitics. Therefore, custom PCB layout should emulate the Evaluation Board PCB layout attached to this design as closely as possible.

All inductors and capacitors must be populated and located as close as possible to ANT pin. Use ceramic multi-layer inductors for effective filtering. Depending on layout, all inductor and capacitor values may require minor value tweaks for optimum impedance matching.

Figure 5. 8TR8219 Application Schematic

Table 10. 8TR8219 Application Bill of Materials (BOM)

Component	Value	Manufacturer	Mfr Part Number	Size	Description
R1, R2	10 kΩ	Panasonic	ERJ-1GNF1002C	0201	RES SMD 10K OHM 1% 1/20W 0201
R5, R6	100 kΩ	Panasonic	ERJ-1GNF1003C	0201	Thick Film Resistors 100 kΩ 50mW 0201
C1	3.3 pF	muRata	GRM0335C1E3R3BA01D	0201	CAP CER 3.3PF 25V COG/NP0 0201
C2	2.2 pF	muRata	GRM0335C1E2R2BA01D	0201	CAP CER 2.2PF 25V COG/NP0 0201
C3	0.2 pF	muRata	GJM0335C1ER20BB01D	0201	CAP CER 0.2PF 25V COG/NP0 0201
C5	100 pF	muRata	GRM0335C1H101JA01D	0201	CAP CER 100PF 50V COG/NP0 0201
C6	1 uF	muRata	GRM155Z71A105KE01J	0402	CAP CER 1UF 10V X7R 0402
L1	1.8 nH	muRata	LQP03TN1N8B02D	0201	Fixed ind 1.8 nH 600mA 150mΩ
L2	0 Ω	Panasonic	ERJ-1GN0R00C	0201	RES SMD 0 OHM JUMPER 1/20W 0201
J1, J2	SMA	Gigalane	PAF-S05-008	End launch	SMA 50 Ohm End Launch Jack Receptacle
J3, J4	10x2	Adam Tech	PH2RA-08-UA	2x4/2x1	HEADER DR RA TH 2X4/ 2x1
U1	8TR8219	BeRex	8TR8219	QFN 3x3	2.4GHz ZigBee/Thread/Bluetooth Smart FEM
C4, R3, R4	DNI			0201	

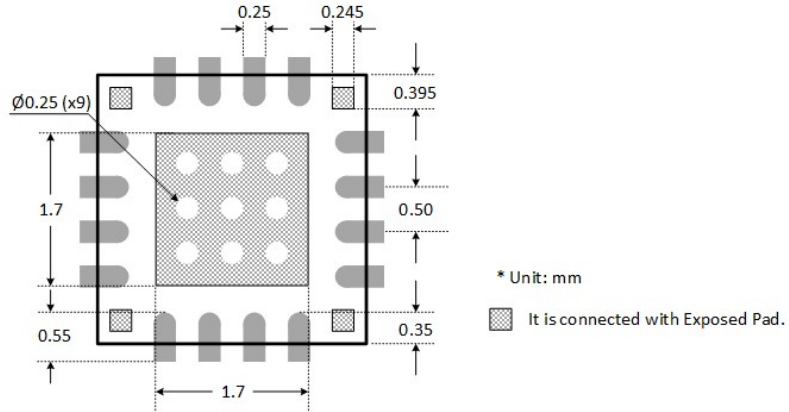
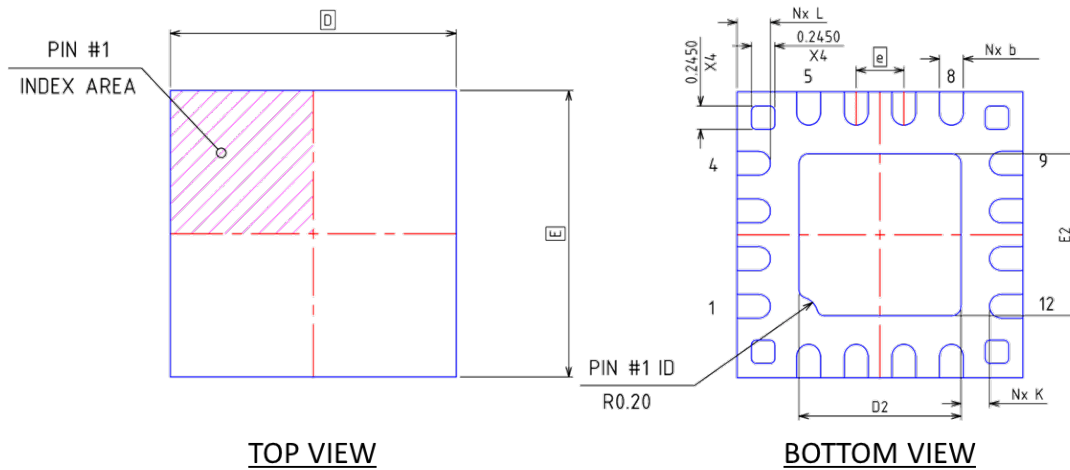
Package Dimensions

Figure 6. 8TR8219 PCB Layout Footprint

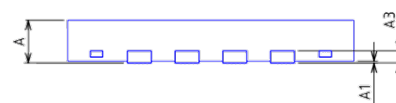
	MIN.	NOM.	MAX.
A	0.41	0.45	0.50
A1	0.00	0.02	0.05
A3	---	0.127 Ref	---
b	0.18	0.25	0.30
D	3.00 BSC		
E	3.00 BSC		
e	0.50 BSC		
D2	1.55	1.70	1.80
E2	1.55	1.70	1.80
K	0.20	---	---
L	0.25	0.35	0.45
N	16		

SIDE VIEW
Figure 7. 8TR8219 Package Dimension

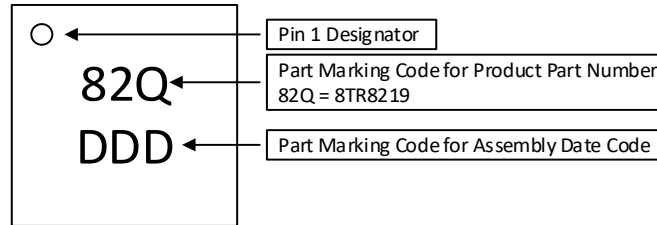
Package Marking



Note: The part marking: 82Q represents the Product Part Number: 8TR8219.

Due to the size limitations of this package, only three (3) characters can be marked on each of two (2) rows. Therefore the Product Part Number is represented in the part marking by a 3-character code.

Figure 8. 8TR8219 Typical Part Marking

ESD Handling Information

Electro Static Discharge (ESD) can cause immediate (or latent) failures in semiconductor Integrated Circuits (ICs). BeRex, Inc. RFIC products are designed with integral ESD protection structures, and all IC products are tested to meet industry standards for ESD event survival. Users must adhere to all precautions for handling ESD sensitive devices throughout the manufacturing, test, shipping, handling, or operational processes, and during field service operations in order to achieve optimum system performance and life expectancy. Production quantities of this product are shipped in a standard tape and reel format.

RoHS Compliance

This part is compliant with Restrictions on the Use of Certain Hazardous Substances in Electrical and Electronic Equipment (RoHS) Directive 2011/65/EU as amended by Directive 2015/863/EU.

This part is lead-free, halogen-free and compliant with a concentration of the Substances of Very High Concern (SVHC) candidate list which are contained in a quantity of less than 0.1%(w/w) in each component of a product and/or its packaging placed on the European Community market by the BeRex and Suppliers.

Tape & Reel

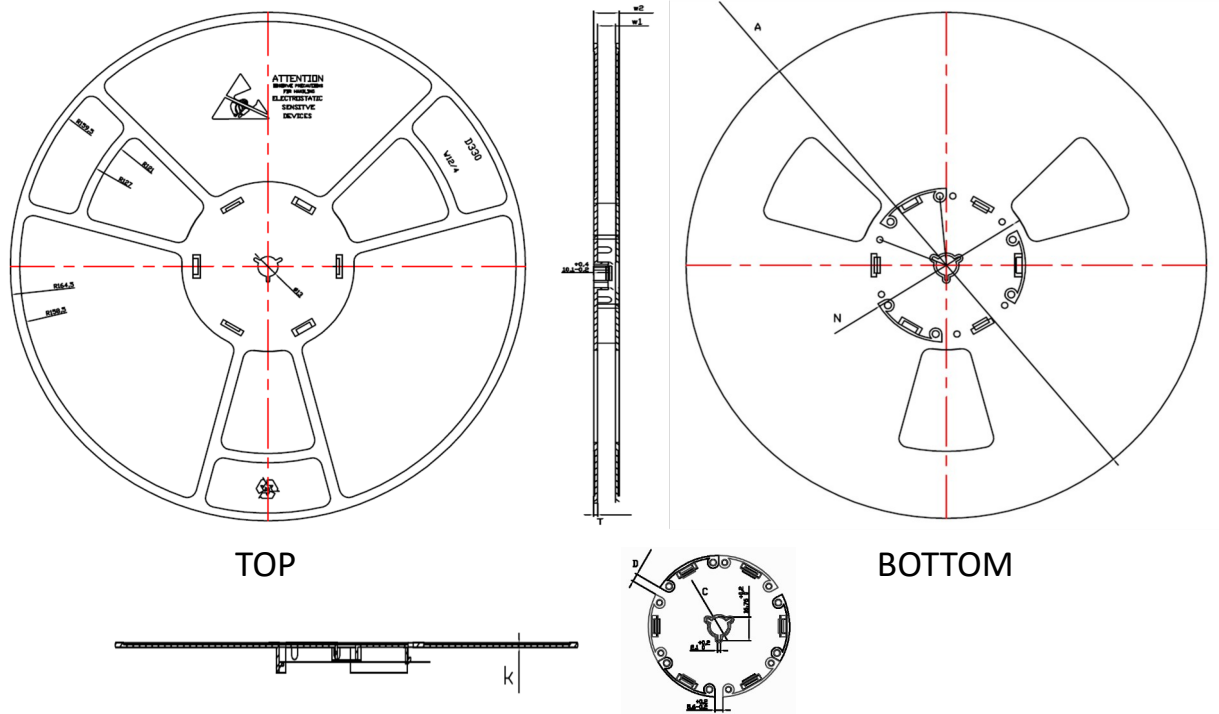

TYPE	A	N	C	D	w1	w2	T	k
12MM	$\phi 330^{+2}_{-2}$	$\phi 100^{+2}_{-2}$	$\phi 13,1^{+0,2}_{-0,2}$	$5,6^{+0,5}_{-0,5}$	$12,4^{+2}_{-0}$	$16,6^{+2}_{-0}$	$2,1 \pm 0,15$	$1,4^{+0,15}_{-0,1}$

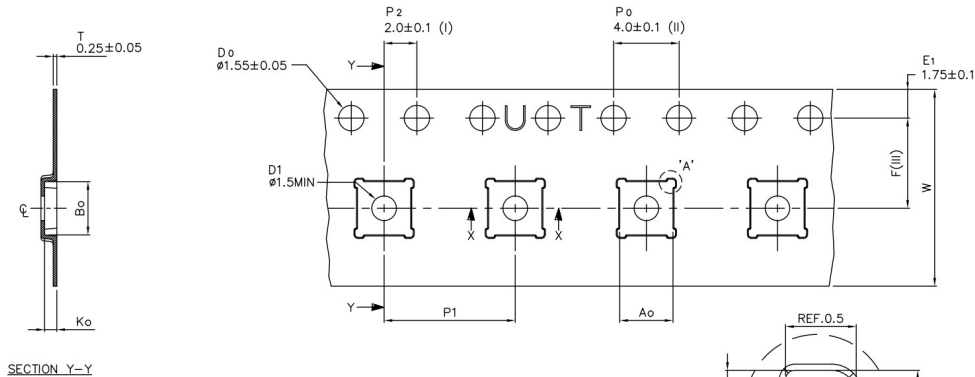

Ao	3.25 +/−0.1
Bo	3.25 +/−0.1
Ko	0.75 +/−0.1
F	5.50 +/−0.1
P1	8.00 +/−0.1
W	12.00 +/−0.3

- (I) Measured from centreline of sprocket hole to centreline of pocket.
- (II) Cumulative tolerance of 10 sprocket holes is ± 0.20.
- (III) Measured from centreline of sprocket hole to centreline of pocket.
- (IV) Other material available.

ALL DIMENSIONS IN MILLIMETRES UNLESS OTHERWISE STATED.

Figure 9. 8TR8219 Tape and Reel Dimension