

### Features

- Single-Chip CMOS Front-End IC
- 4-Port Antenna Switch for Angle-of-Arrival (AoA) / Angle-of-Departure (AoD) Location Detection
- 2.4 - 2.5GHz Frequency Range
- Nearly Constant Tx Output Power over VSWR
- Up to 5dBm EDR Output Power
- Transmit Power Stable over Antenna Mismatch
- Low Noise Figure, and Low-Current LNA Mode
- Throttle-down mode for fast switching
- Temperature Range: -40°C to 125°C
- 2.7V to 3.6V Operating Voltage
- 3mm x 3mm x 0.55mm 20-pin QFN Package
- Die in Wafer Form Available

### Applications

- AoA/AoD Indoor Location and Position Tracking
- IoT Nodes, Gateways, and Beacons
- M2M (Machine to Machine) Wireless
- ZigBee, Thread, ANT+
- Smart: Home, City, Lighting, and Energy
- Industrial and Building Automation
- Consumer and Wearable Wireless Electronics

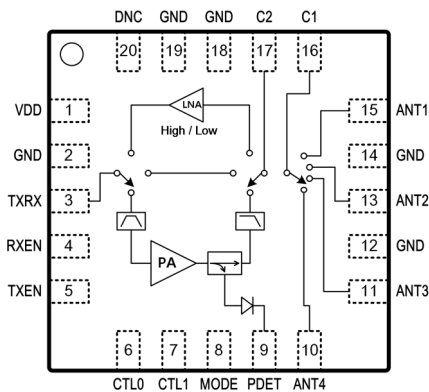
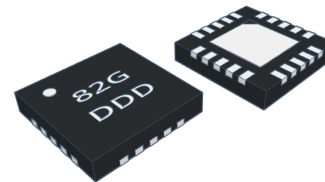

**Figure 1: Functional Block Diagram**

### Description

The 8TR8241 is a Single-Chip CMOS RF Front-End IC that combines: Power Amplifier, Low Noise Amplifier, Bypass, Transmit / Receive Switch, 4-Port Antenna Switch, Directional Power Detector, and Matching Network. Transmitted Power is stable over Antenna mismatch at any phase angle. It is intended for Zigbee, Thread, as well as ANT/ANT+, and Proprietary ISM Wireless Systems in the 2.4GHz Band. Wide operating Supply Voltage (2.7V – 3.6V) and wide Temperature Range (-40°C to 125°C) support battery-powered wireless systems.

The 8TR8241 is RoHS compliant, halogen-free, and REACH Compliant. It is rated for Moisture Sensitivity Level 1 (MSL1), reflow at 260°C per JEDEC J-STD-020. Refer to IPC/JEDEC J-STD-020 for detailed solder reflow temperature and profile.



20-Lead 3mm x3mm x 0.55mm, QFN Package

**Figure 2: Package Type**

### Ordering Information

Part Number	Description
8TR8241	2.4GHz Front-End RFIC in 3mm x 3mm x 0.55mm 20-Pin QFN
8TR8241-EVB	Fully Tested and Characterized Evaluation Board
8TR8241-DWF	2.4GHz Front-End RFIC Die in Wafer Form

### Pin Descriptions

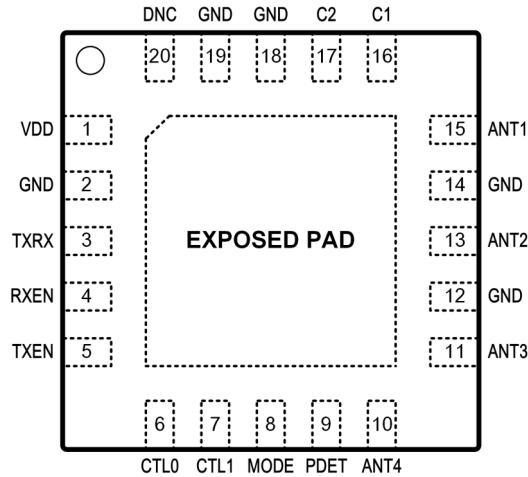

Figure 3 :Pin Description (Top View)

Table 1: 8TR8241 Pin Signal Description

Pin	Name	Description	Pin	Name	Description
1	VDD	DC Voltage Supply	11	ANT3	Antenna 3 Port (DC shorted to GND)
2	GND	Ground	12	GND	Ground
3	TXRX	Transmit /Receive Port (DC shorted to GND)	13	ANT2	Antenna 2 Port (DC shorted to GND)
4	RXEN	Control Logic Pin	14	GND	Ground
5	TXEN	Control Logic Pin	15	ANT1	Antenna 1 Port (DC shorted to GND)
6	CTL0	Control Logic Pin	16	C1	Internal Filter Port* (DC shorted to GND)
7	CTL1	Control Logic Pin	17	C2	Internal Filter Port* (DC shorted to GND)
8	MODE	Control Logic Pin	18	GND	Ground
9	PDET	Power detector voltage	19	GND	Ground
10	ANT4	Antenna 4 Port (DC shorted to GND)	20	DNC	Do Not Connect
EXPOSED PAD		Exposed pad should be connected to GND.			

Preliminary Datasheet

**General Specifications**
**Table 2: 8TR8241 Absolute Maximum Ratings**

Parameter	Units	Minimum	Maximum
Supply Voltage (VDD)	V	0	3.7
Supply Current (I <sub>dd</sub> )	mA		50
Control Logic Pin (TXEN, RXEN, MODE, CTL0, CTL1)	V	0	VDD
Transmit Input Power at TXRX Port	dBm		10
Receive Input Power at ANT Port	dBm		7
Bypass Mode Input Power	dBm		20
Storage Temperature	°C	-40	150

Note: Sustained operation at or above the Absolute Maximum Ratings for any single or combinations of the above parameters may result in permanent damage to the device and is not recommended. All Maximum RF Input Power Ratings assume 50Ω terminal impedance.

**Table 3: 8TR8241 Recommended Operating Conditions**

Parameter	Units	Minimum	Typical	Maximum
Supply Voltage (VDD, recommended)	V	2.7	3.3	3.6
Supply Voltage (VDD, extend supply voltage)**	V	1.8		3.6
Control Pin - Logic High State	V	1.2		VDD*
Control Pin - Logic Low State	V	0		0.4
Operating Frequency Range	GHz	2.4		2.5
Operating Temperature	°C	-40	25	125

\* For Control Voltages > 3.0V, a 10kΩ series resistor should be used at the Control Logic Pins.

\*\* Functional working with degraded performance for the supply voltage range 1.8V to 2.7V.

**Table 4: 8TR8241 Transmit Electrical Specifications**

(VDD = 3.3V, T<sub>Ambient</sub> = 25°C, With External Harmonic Filter, Excluding PCB and Connector Loss, Unless Otherwise Noted)

Parameter	Units	Min	Typ	Max	Test Conditions
Frequency Range	GHz	2.4		2.5	
Saturated Output Power	dBm		12		VDD: 2.7V
			13		VDD: 3.0V
			14		VDD: 3.3V
EDR Spectral Mask	dBm		5		Spectral Mask compliant, 3Mbps EDR signal
Large-Signal Gain	dB		11		VDD: 2.7V, 10dBm Pout
			11		VDD: 3.0V, 10dBm Pout
			11		VDD: 3.3V, 10dBm Pout
TX Large-Signal Gain variation over Antennas	dB			0.5	
Current Consumption	mA		17		10dBm Pout
			22		12dBm Pout
TX Quiescent Current	mA		5		No RF applied
Second Harmonic	dBm/MHz		-45		Up to +12dBm Output power
Third Harmonic	dBm/MHz		-45		
Power Detector Voltage (PDET)*	V		0.4		0dBm Pout
			0.9		12dBm Pout
Input Return Loss	dB		-9		
Output Return Loss	dB		-9		
Load VSWR for Stability			6:1		All Non-harmonic Spurs Less than -50dBm/MHz
Load VSWR for Ruggedness			10:1		No Damage at +10dBm input power

\*Make the PDET pin No Connect if the power detector function is not used.

**Table 5: 8TR8241 Receive and Bypass Electrical Specifications**

(VDD = 3.3V, T<sub>Ambient</sub> = 25°C, With External Harmonic Filter, Excluding PCB and Connector Loss, Unless Otherwise Noted)

Parameter	Units	Min	Typ	Max	Test Conditions
Operating Frequency Band	GHz	2.4		2.5	
RX Small Signal Gain	dB		13		RX High Gain Mode
			11		RX Low Current Mode
RX Small-Signal Gain variation over Antenna	dB		0.5		
RX Current Consumption	mA		9.5		RX High Gain Mode
			6		RX Low Current Mode
Noise Figure	dB		3.8		RX High Gain Mode
			4.1		RX Low Current Mode
RX Input P1dB	dBm		-10		
RX Input Return Loss	dB		-7		
RX Output Return Loss	dB		-11		
Bypass Insertion Loss	dB		5		
Bypass Current Consumption	uA		4		

**Table 6: 8TR8241 Switching Time Specifications**

 (VDD = 3.3V, T<sub>Ambient</sub> = 25°C, With External Harmonic Filter, Unless Otherwise Noted)

Parameter	Units	Min	Typ	Max	Test Conditions
TX to RX	usec		0.45		From 50% of RXEN to 90% RX Power
Shutdown to RX	usec		0.48		From 50% of MODE to 90% RX Power
Bypass to RX	usec		0.50		From 50% of RXEN to 90% RX Power
RX to TX	usec		0.42		From 50% of TXEN to 90% RF
Shutdown to TX	usec		0.43		From 50% of MODE to 90% RF
RX to Bypass	usec		0.27		From 50% of TXEN to 90% RF
Shutdown to Bypass	usec		0.28		From 50% of MODE to 90% RF
Throttle-Down*	usec	0.05		0.38	

\* Refer to Application Note for the explanation on Throttle-Down.

**Table 7: 8TR8241 Antenna Switch Specifications**

 (VDD = 3.3V, T<sub>Ambient</sub> = 25°C, With External Harmonic Filter, Excluding PCB and Connector Loss, Unless Otherwise Noted)

Parameter	Units	Min	Typ	Max	Test Conditions
Antenna Switch Insertion Loss	dB		1		Without harmonic filter
Antenna Switch Isolation	dB		35		Ant1 to Ant2, Ant3 and Ant4
Antenna Switching Time	usec		0.45		From 50% of CTL0/CTL1 to 90% RF*
			0.12		From 50% of CTL0/CTL1 to 10% RF*

\* RF power is already turned on (either TX or RX)

**Table 8: 8TR8241 Leakage Current Specifications**

 (VDD = 3.3V, T<sub>Ambient</sub> = 25°C, Unless Otherwise Noted)

Parameter	Units	Min	Typ	Max	Test Conditions
Shutdown Mode VDD Leakage Current	uA		1.0		
Control Pin Current (Logic High, 1.8V)	uA		0.1		

**Table 9: 8TR8241 Control Logic**
**Operation Mode control Logic Table**

"1" = Logic High, "0" = Logic Low

TXEN	RXEN	MODE	Operational Mode
0	0	0	Shutdown
0	0	1	Bypass*
0	1	0	RX High Gain mode
0	1	1	RX Low Current mode
1	0	0	TX without Det
1	0	1	Throttle-Down, without Det
1	1	0	TX with Det
1	1	1	Throttle-Down, with Det

\* The Bypass Mode consumes no more current than the shutdown mode.

**Antenna Select Logic Table**

CTL0	CTL1	Operational Mode
0	0	ANT1
0	1	ANT2
1	0	ANT3
1	1	ANT4

### Application Notes

The 8TR8241 Application note provides detailed descriptions and test data over various operating conditions. Visit [www.berex.com](http://www.berex.com) or contact BeRex at [sales@berex.com](mailto:sales@berex.com) to request additional documentation.

### Application Schematic and PCB Layout

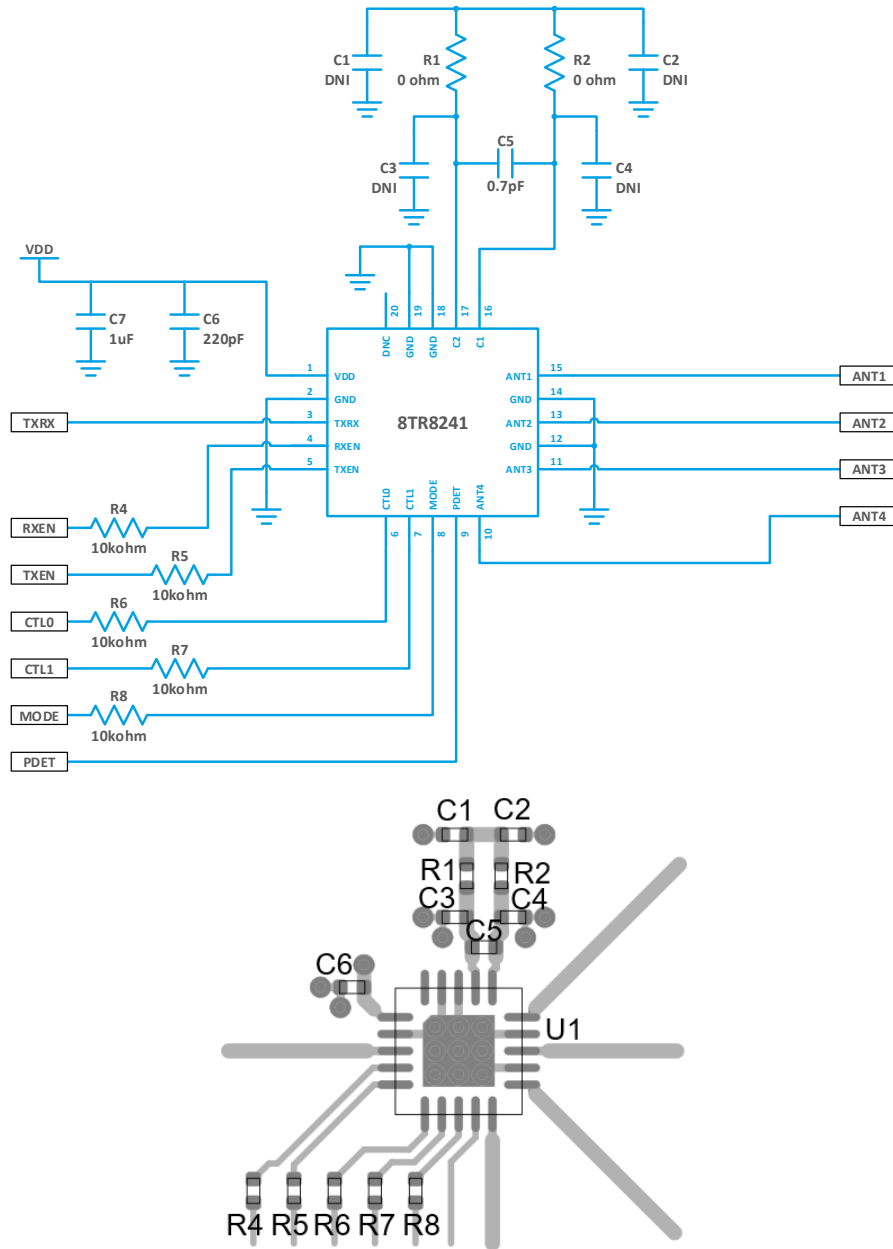

Note : Refer to 8TR8241 application note for more information.

**Figure 4: 8TR8241 Reference Design Schematic and PCB Layout**

### Package Dimensions

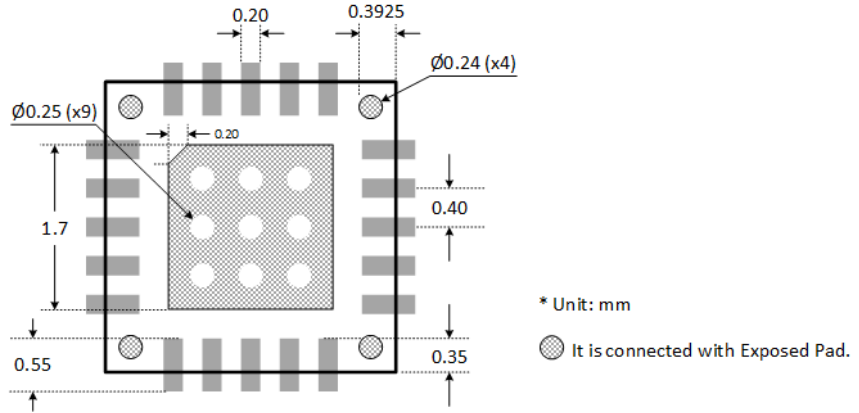
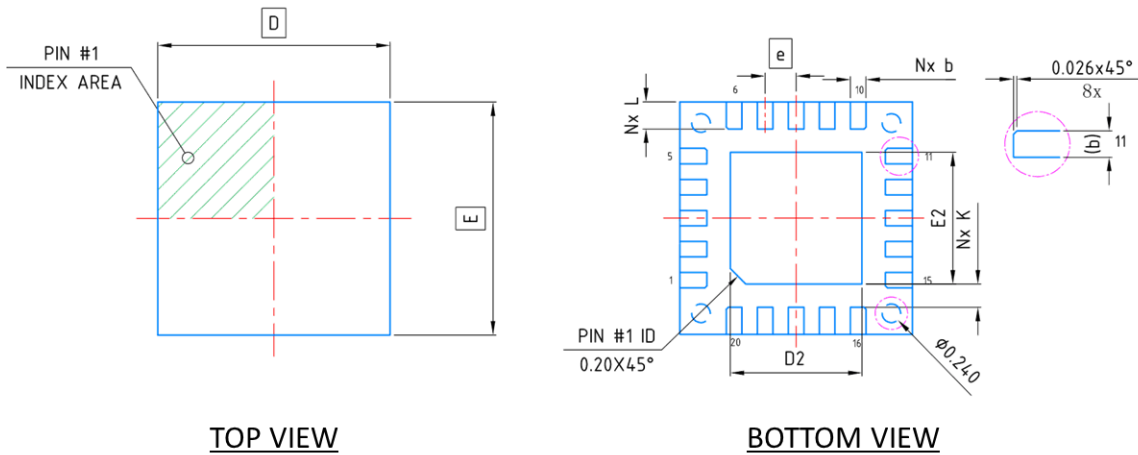
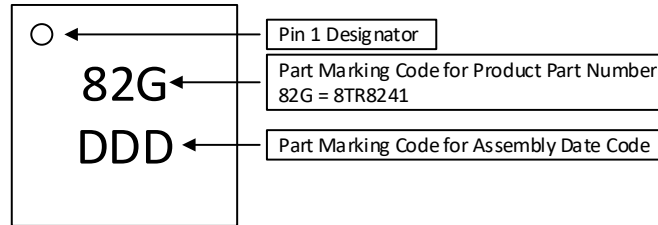

Figure 5: 8TR8241 Recommended PCB Layout Footprint



	MIN.	NOM.	MAX.
A	0.51	0.55	0.60
A1	0.00	0.02	0.05
A3	---	0.152 Ref	---
b	0.15	0.20	0.25
D	3.00 BSC		
E	3.00 BSC		
e	0.40 BSC		
D2	1.55	1.70	1.80
E2	1.55	1.70	1.80
K	0.20	---	---
L	0.25	0.35	0.45
N	20		

Figure 6: 8TR8241 Package Dimension

**Package Marking**

Note: The part marking: 82G represents the Product Part Number: 8TR8241.

Due to the size limitations of this package, only three (3) characters can be marked on each of two (2) rows. Therefore the Product Part Number is represented in the part marking by a 3-character code.

**Figure 7: 8TR8241 Part Marking Code**

**ESD Handling Information**

Electro Static Discharge (ESD) can cause immediate (or latent) failures in semiconductor Integrated Circuits (ICs). BeRex, Inc. RFIC products are designed with integral ESD protection structures, and all IC products are tested to meet industry standards for ESD event survival. Users must adhere to all precautions for handling ESD sensitive devices throughout the manufacturing, test, shipping, handling, or operational processes, and during field service operations in order to achieve optimum system performance and life expectancy. Production quantities of this product are shipped in a standard tape and reel format.

**RoHS Compliance**

This part is compliant with Restrictions on the Use of Certain Hazardous Substances in Electrical and Electronic Equipment (RoHS) Directive 2011/65/EU as amended by Directive 2015/863/EU.

This part is lead-free, halogen-free and compliant with a concentration of the Substances of Very High Concern (SVHC) candidate list which are contained in a quantity of less than 0.1%(w/w) in each component of a product and/or its packaging placed on the European Community market by the BeRex and Suppliers.



### Tape & Reel

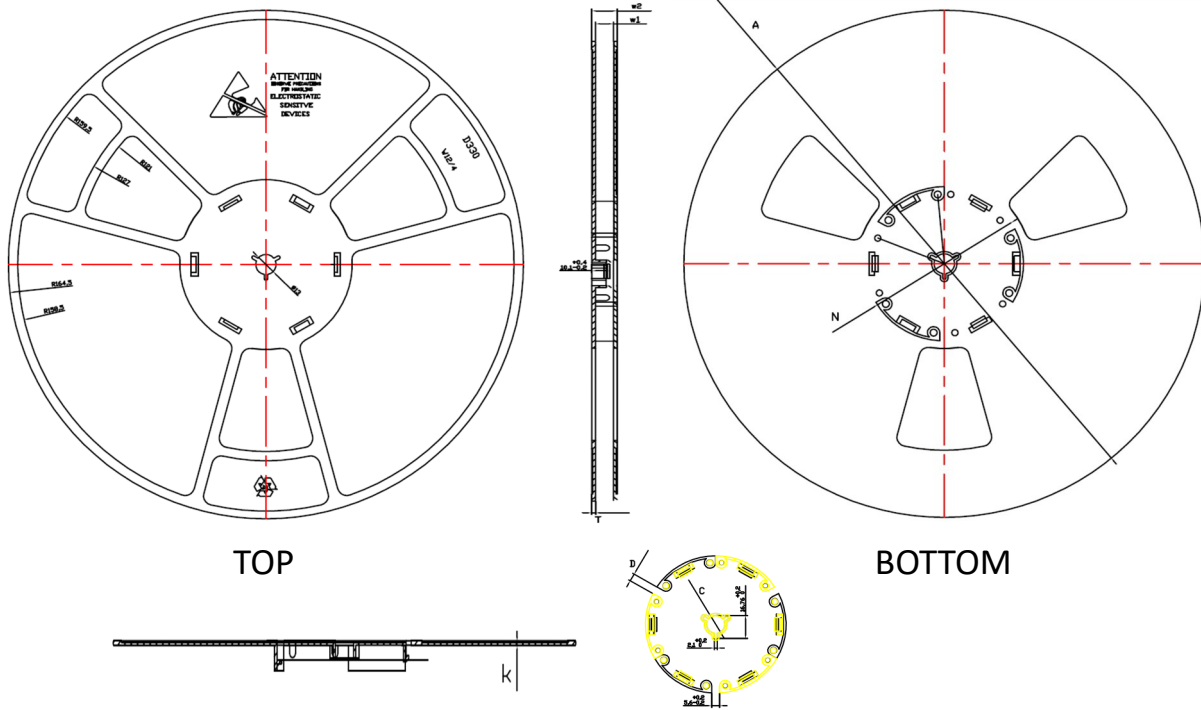

TYPE	A	N	C	D	w1	w2	T	k
12MM	$\phi 330^{+2}_{-2}$	$\phi 100^{+2}_{-2}$	$\phi 13,1^{+0,2}_{-0,2}$	$5,6^{+0,5}_{-0,5}$	$12,4^{+2}_{-0}$	$16,6^{+2}_{-0}$	$2,1 \pm 0,15$	$1,4^{+0,15}_{-0,1}$

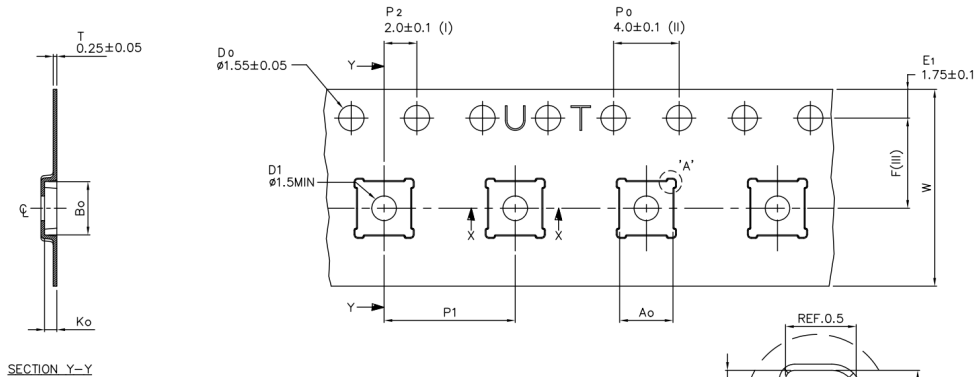

Ao	3.25 +/−0.1
Bo	3.25 +/−0.1
Ko	0.75 +/−0.1
F	5.50 +/−0.1
P1	8.00 +/−0.1
W	12.00 +/−0.3

- (I) Measured from centreline of sprocket hole to centreline of pocket.
- (II) Cumulative tolerance of 10 sprocket holes is ± 0.20.
- (III) Measured from centreline of sprocket hole to centreline of pocket.
- (IV) Other material available.

ALL DIMENSIONS IN MILLIMETRES UNLESS OTHERWISE STATED.

**Figure 8: 8TR8241 Tape and Reel Dimension**