

1. RF MMIC Innovator

www.berex.com

Classification: Application Note

Document Number: 14B_80902

Revision code: 0.2

Wide Band Gain Block BG14B

Application Note



Contents

RF MMIC INNOVATOR WWW.BEREX.COM..... 1

1. BG14B 70MHZ APPLICATION.....3

2. BG14B 70MHZ TEST RESULT4

3. BG14B 120MHZ APPLICATION.....5

4. BG14B 120MHZ TEST RESULT6

5. BG14B WIDEBAND APPLICATION7

6. BG14B WIDEBAND TEST RESULT8

1. BG14B 70MHz Application Note

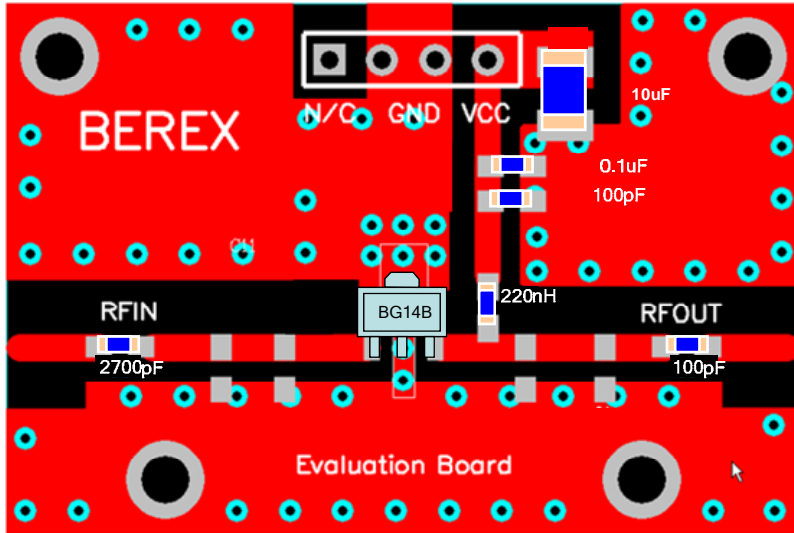

Ref. Des.	Description/ Part Number	Values	Vendor
C1	0603 CAP	100pF	Samsung
C2	604 CAP	0.1uF	Samsung
C3	A3216 CAP	10uF	AVX
C4	0603 CAP	2700pF	Samsung
C5	0603 CAP	100pF	Samsung
C6	0603 CAP	NA	
C7	0603 CAP	NA	
C8	0603 CAP	NA	
C9	0603 CAP	NA	
C10	0603 CAP	NA	
C11	0603 CAP	NA	
C12	0603 CAP	NA	
L1	0603 IND	220nH	Ceratech
L2	0603 IND	NA	
L3	0603 IND	NA	
R1	0603 RES	NA	
U1	SOT89 PKG	BG14B	BEREX

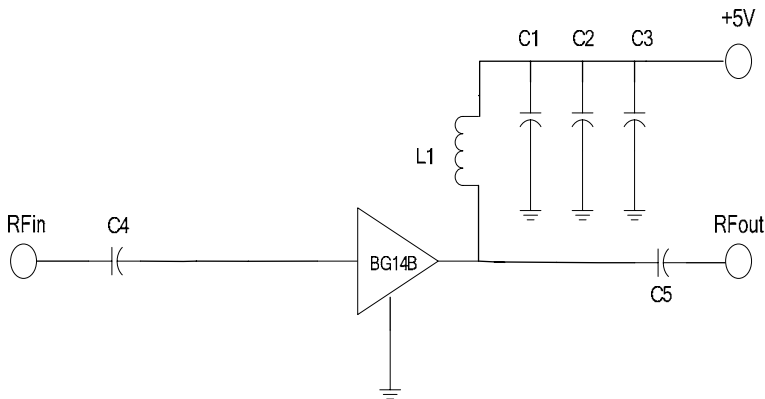

Note:

1. PCB: 31mil thick FR4

TITLE	
BG14B Evaluation Board	
(70MHz)	
Drawing Number	Rev.
Date	Drawn By
FILE NAME	SHEET

2. BG14B 70MHz Test Result

SN	Freq [MHz]	Vcc [V]	Icc [mA]	Gain [dB]	OIP3 [dBm] ⁽¹⁾	P1dB [dBm]	IRL [dB]	ORL [dB]
	70	5	79	17.5	38.5	19.5	-16.4	-16.3

(1) OIP3 was tested @Pout=7dBm/tone 1MHz offset

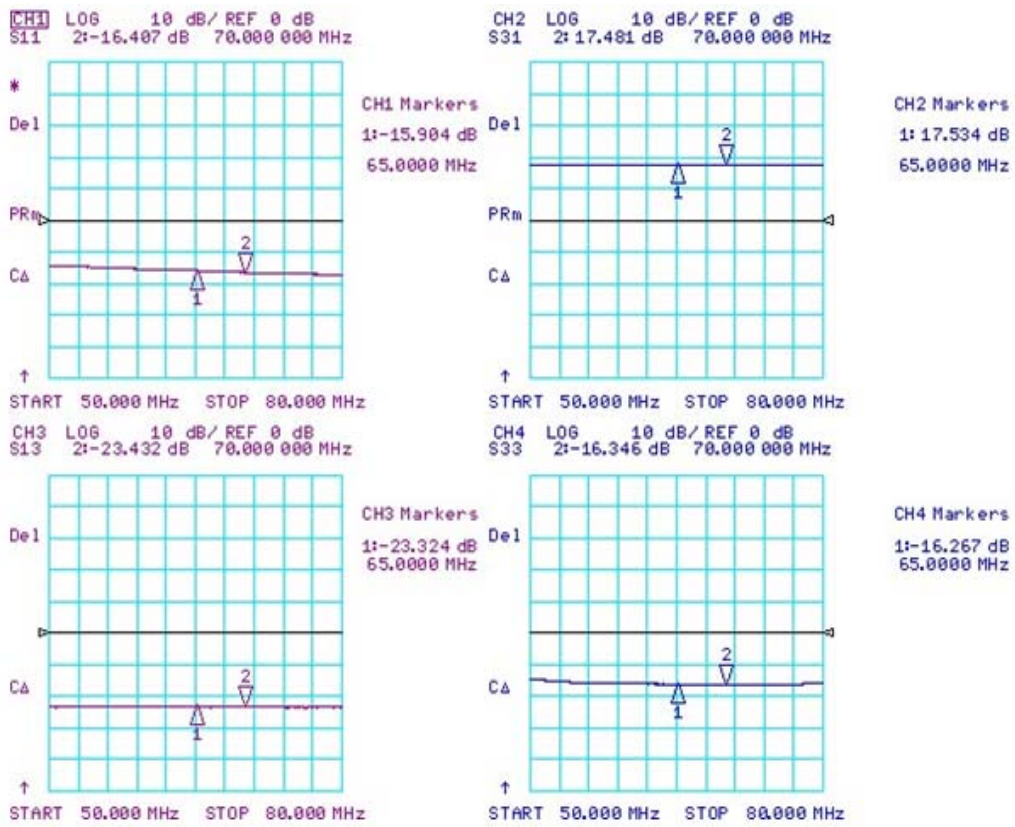

2. BG14B 120MHz Application Note

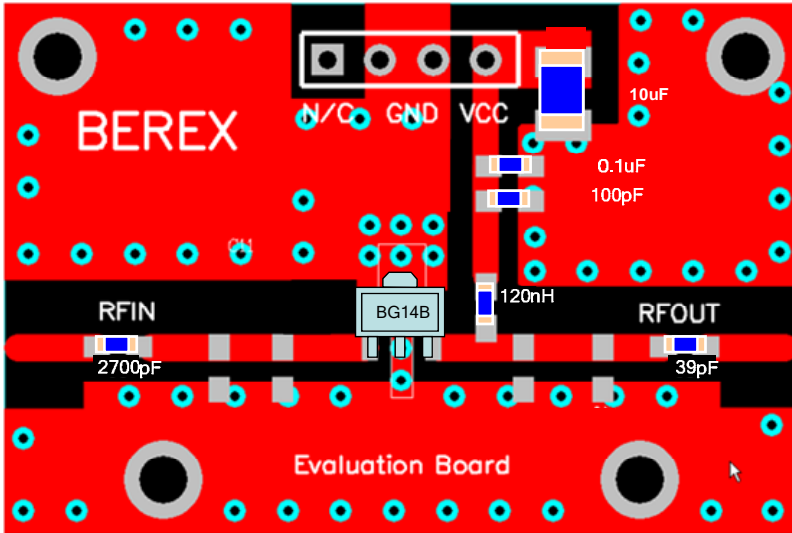

Ref. Des.	Description/ Part Number	Values	Vendor
C1	0603 CAP	100pF	Samsung
C2	604 CAP	0.1uF	Samsung
C3	A3216 CAP	10uF	AVX
C4	0603 CAP	2700pF	Samsung
C5	0603 CAP	39pF	Samsung
C6	0603 CAP	NA	
C7	0603 CAP	NA	
C8	0603 CAP	NA	
C9	0603 CAP	NA	
C10	0603 CAP	NA	
C11	0603 CAP	NA	
C12	0603 CAP	NA	
L1	0603 IND	120nH	Ceratech
L2	0603 IND	NA	
L3	0603 IND	NA	
R1	0603 RES	NA	
U1	SOT89 PKG	BG14B	BEREX

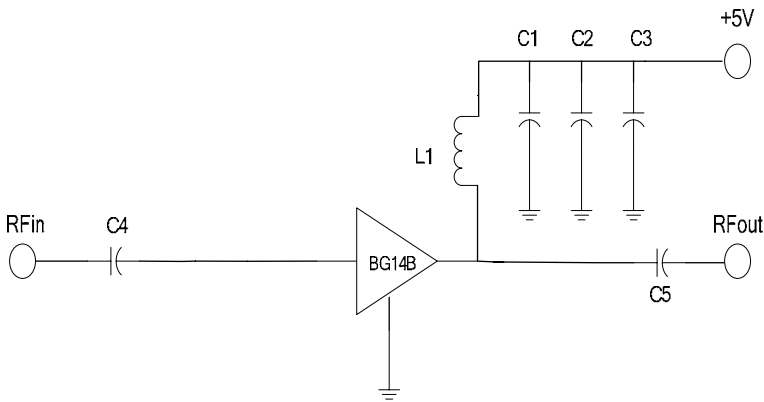

Note:

- 3. PCB: 31mil thick FR4

TITLE	
BG14B Evaluation Board	
(120MHz)	
Drawing Number	Rev.
Date	Drawn By
FILE NAME	SHEET

4. BG14B 120MHz Test Result

SN	Freq [MHz]	Vcc [V]	Icc [mA]	Gain [dB]	OIP3 [dBm] ⁽¹⁾	P1dB [dBm]	IRL [dB]	ORL [dB]
	120	5	79	17.7	39	19.5	-13.9	-24.4

(1) OIP3 was tested @Pout=7dBm/tone 1MHz offset

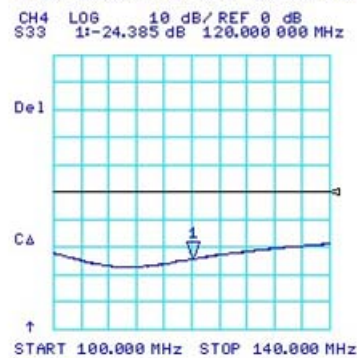
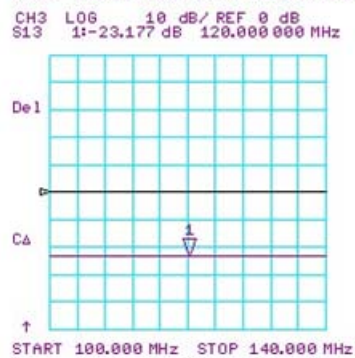
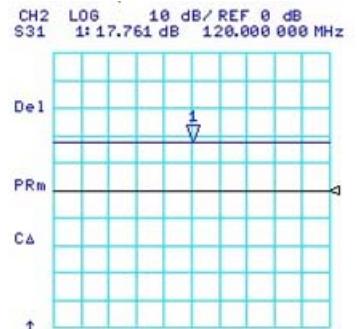
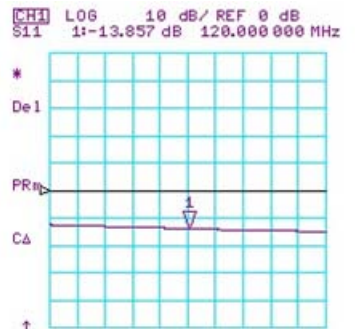

3. BG14B Wide Band Application

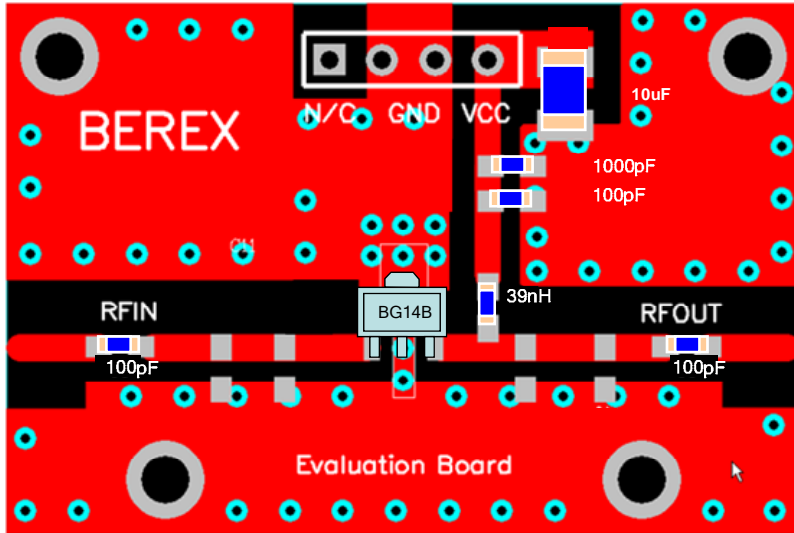

Ref. Des.	Description/ Part Number	Values	Vendor
C1	0603 CAP	100pF	Samsung
C2	604 CAP	0.1uF	Samsung
C3	A3216 CAP	10uF	AVX
C4	0603 CAP	100pF	Samsung
C5	0603 CAP	100pF	Samsung
C6	0603 CAP	NA	
C7	0603 CAP	NA	
C8	0603 CAP	NA	
C9	0603 CAP	NA	
C10	0603 CAP	NA	
C11	0603 CAP	NA	
C12	0603 CAP	NA	
L1	0603 IND	39nH	Ceratech
L2	0603 IND	NA	
L3	0603 IND	NA	
R1	0603 RES	NA	
U1	SOT89 PKG	BG14B	BEREX

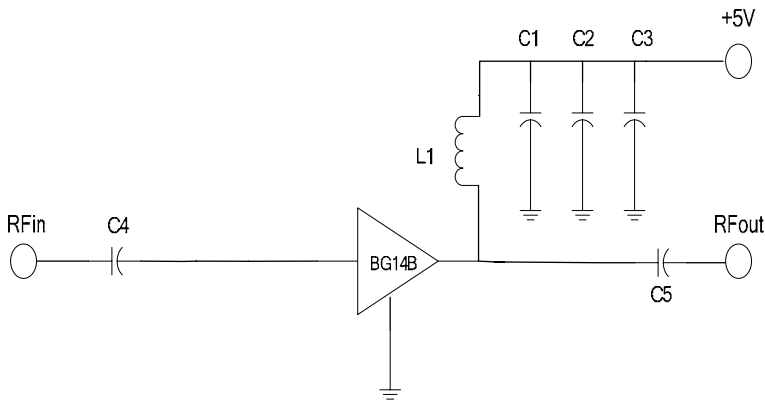

Note:

- 5. PCB: 31mil thick FR4

TITLE	
BG14B Evaluation Board	
(Wide Band)	
Drawing Number	Rev.
Date	Drawn By
FILE NAME	SHEET

6. BG14B Wide Band Test Result

SN	Freq [MHz]	Vcc [V]	Icc [mA]	Gain [dB]	OIP3 [dBm] ⁽¹⁾	P1dB [dBm]	IRL [dB]	ORL [dB]
	500	5	79	17.3	37.5	19.5	-18.5	-14.0
	900	5	79	17.2	36.5	19.5	-17.5	-15.0
	1900	5	79	16.4	35.0	19.5	-27.5	-10.5
	2140	5	79	16.1	34.5	19.5	-23.0	-11.5
	2450	5	79	15.8	33.5	19.5	-19.0	-10.0
	3000	5	79	15.8	32.5	19.5	-16.0	-13.0

(1) OIP3 was tested @Pout=7dBm/tone 1MHz offset

