

RF MMIC Innovator

www.berex.com

[CLASSIFICATION] APPLICATION NOTE

[DATE] 2024. 07

[REVISION NO.] REV.B

[MEASURING INSTRUMENTS]

- NA_AGILENT E5071B

- SA_AGILENT N9020A

- SG_AGILENT 4438C

- SG_IFR 3416

Si-Ge Gain Block Amp BGS2

Application Note



Contents

RF MMIC INNOVATOR WWW.BEREX.COM 1

1. 3500MHZ APPLICATION 3

 1.1 3500MHZ TEST RESULT(S-PARAMETER, OIP3, P1, NF,ACLR) 4

 1.2 3500MHZ LTE_20MHZ_ACLR TEST RESULT 5

2. 3700MHZ APPLICATION 6

 2.1 3700MHZ TEST RESULT(S-PARAMETER, OIP3, P1, NF,ACLR) 7

 2.2 3700MHZ LTE_20MHZ_ACLR TEST RESULT 8

1. BGS2_ 3500MHz Application Note

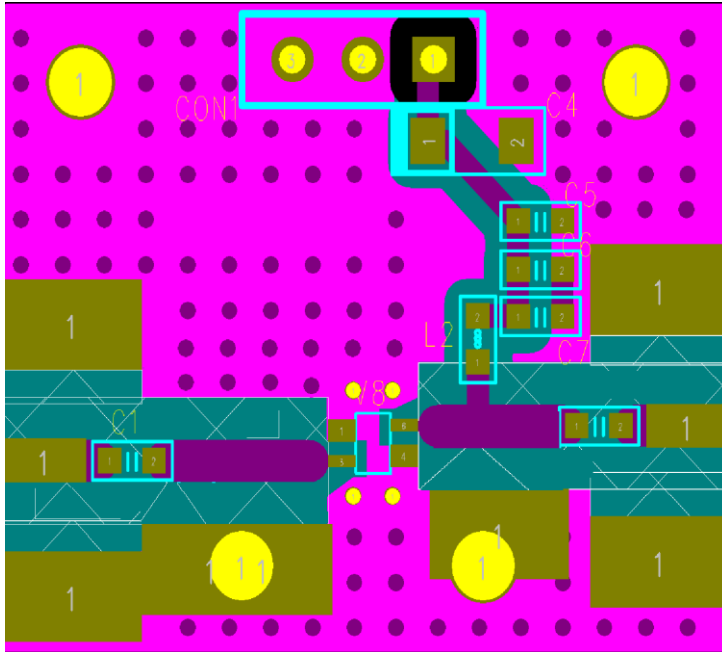

Ref. Des.	Description/ Part Number	Values	Vendor
C1	0603 CAP	100pF	Samsung
C2	0603 CAP	100pF	Samsung
C3	0603 CAP	100pF	Samsung
C4	0603 CAP	1000pF	Samsung
C5	A3216 CAP	10uF	AVX
L1	0603 CAP	27nH	Samsung
U1	SOT363 PKG	BGS2	BEREX

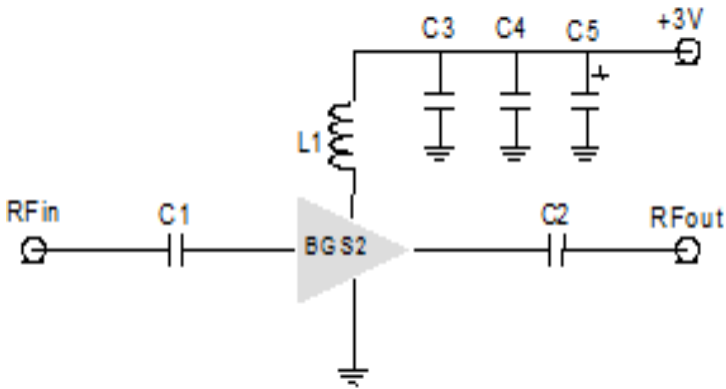

Note:

1. PCB: 31mil thick FR4

TITLE	
BGS2 Evaluation Board	
(3500MHz)	
Drawing Number	Rev.
Date	Drawn By
FILE NAME	SHEET

1.1 BGS2_3500MHz Test Result

SN	Freq [MHz]	Vcc [V]	Icc [mA]	Gain [dB]	OIP3 [dBm] ⁽¹⁾	P1dB [dBm]	IRL [dB]	ORL [dB]	NF [dB]
-	3400	3.0	37	15.5	19.5	8.9	-13.6	-15.0	2.7
-	3500	3.0	37	15.3	19.2	8.8	-13.2	-14.7	2.8
-	3600	3.0	37	15.3	19.1	8.6	-12.6	-15.3	2.7

(1) OIP3 was tested @Pout=0dBm/tone 1MHz offset

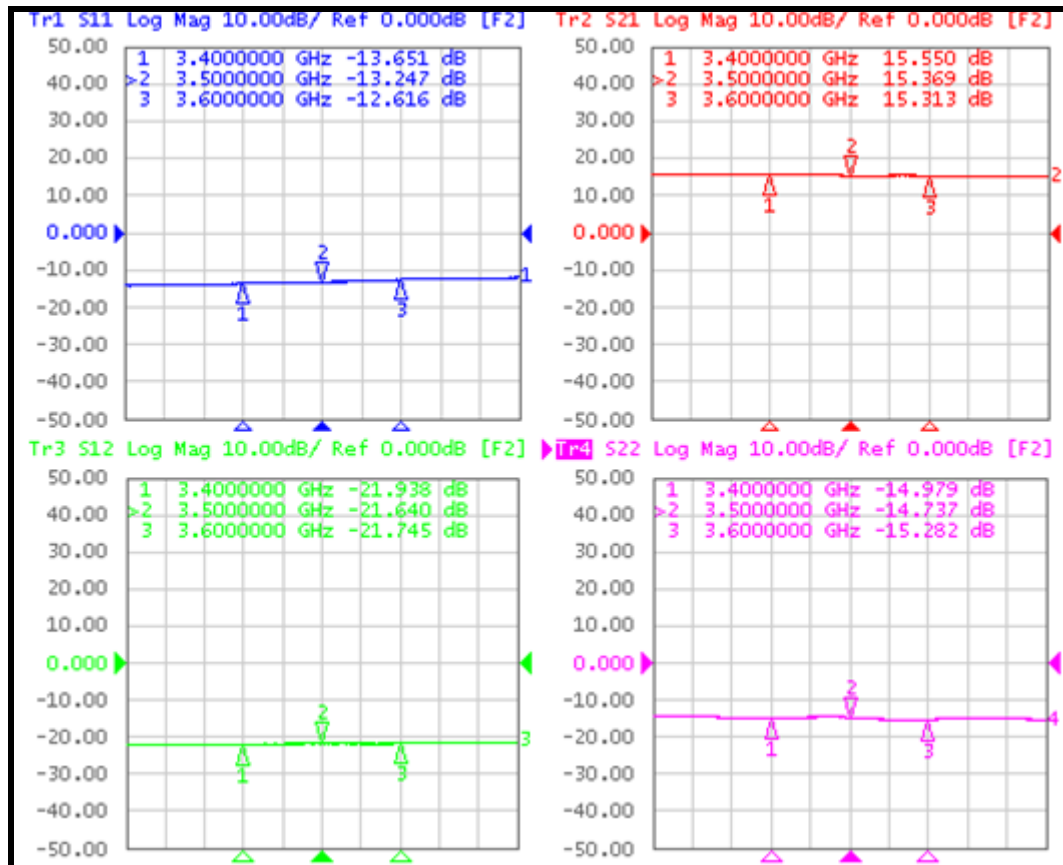

1.2 LTE_20MHz_ACLR Test Result

Out Power : -3.6 dBm

LTE_FDD_20MHz_TM 3p1_100% : 3500MHz -50dBc

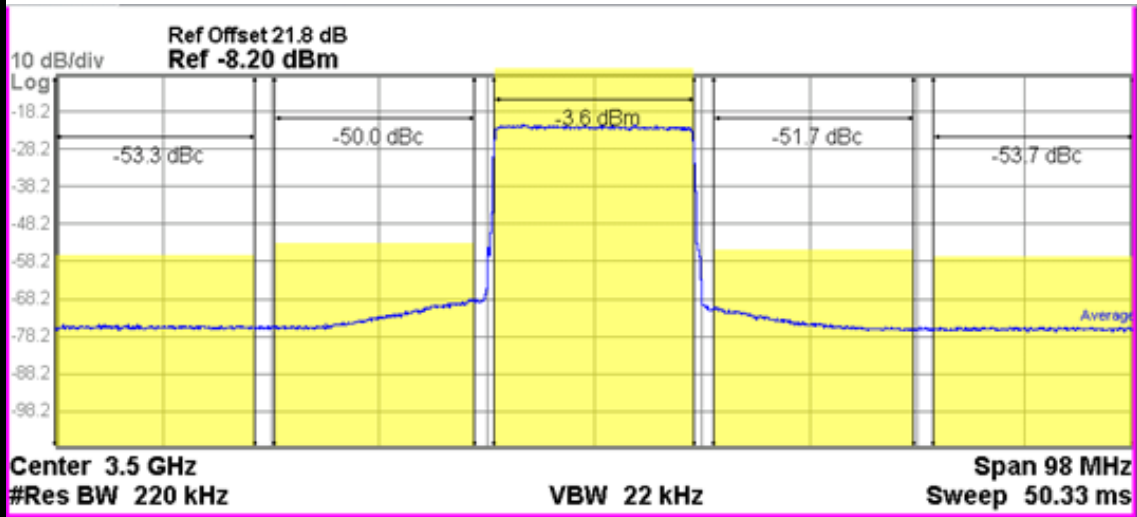

Carrier Power		Filter	Offset Freq	Integ BW	Lower		Upper		Filter
					dBc	dBm	dBc	dBm	
1	-3.591 dBm / 18.00 MHz	OFF	20.00 MHz	18.00 MHz	-50.01	-53.60	-51.70	-55.29	OFF
			40.00 MHz	18.00 MHz	-53.30	-56.89	-53.72	-57.31	OFF

2. BGS2_ 3700MHz Application Note

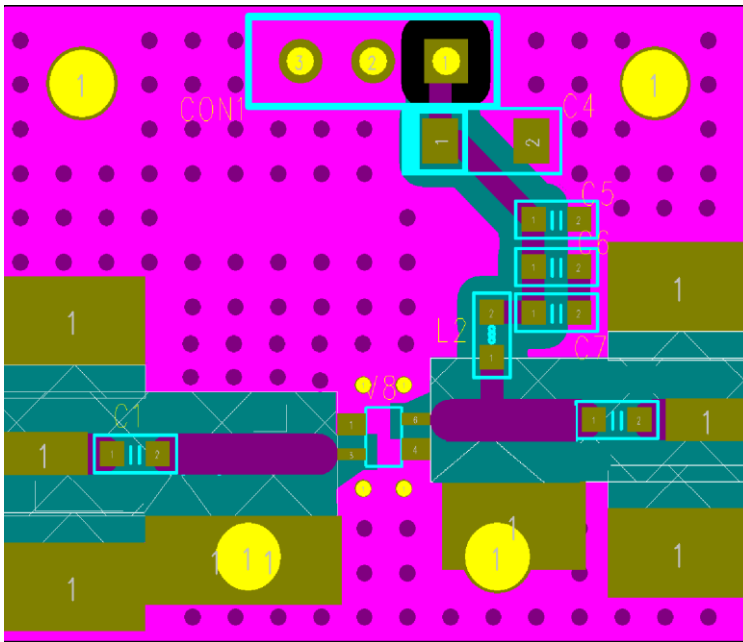

Ref. Des.	Description/ Part Number	Values	Vendor
C1	0603 CAP	100pF	Samsung
C2	0603 CAP	100pF	Samsung
C3	0603 CAP	100pF	Samsung
C4	0603 CAP	1000pF	Samsung
C5	A3216 CAP	10uF	AVX
L1	0603 CAP	27nH	Samsung
U1	SOT363 PKG	BGS2	BEREX

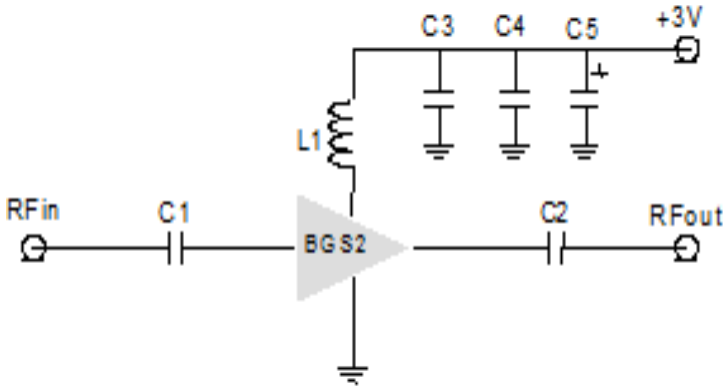

Note:

- 2. PCB: 31mil thick FR4

TITLE	
BGS2 Evaluation Board	
(3700MHz)	
Drawing Number	Rev.
Date	Drawn By
FILE NAME	SHEET

2.1 BGS2_3700MHz Test Result

SN	Freq [MHz]	Vcc [V]	Icc [mA]	Gain [dB]	OIP3 [dBm] ⁽¹⁾	P1dB [dBm]	IRL [dB]	ORL [dB]	NF [dB]
-	3600	3.0	37	15.2	19.1	8.6	-12.6	-15.4	2.7
-	3700	3.0	37	15.1	19.0	8.7	-12.2	-14.9	2.8
-	3800	3.0	37	15.0	18.8	8.5	-11.6	-15.3	2.8

(1) OIP3 was tested @Pout=0dBm/tone 1MHz offset

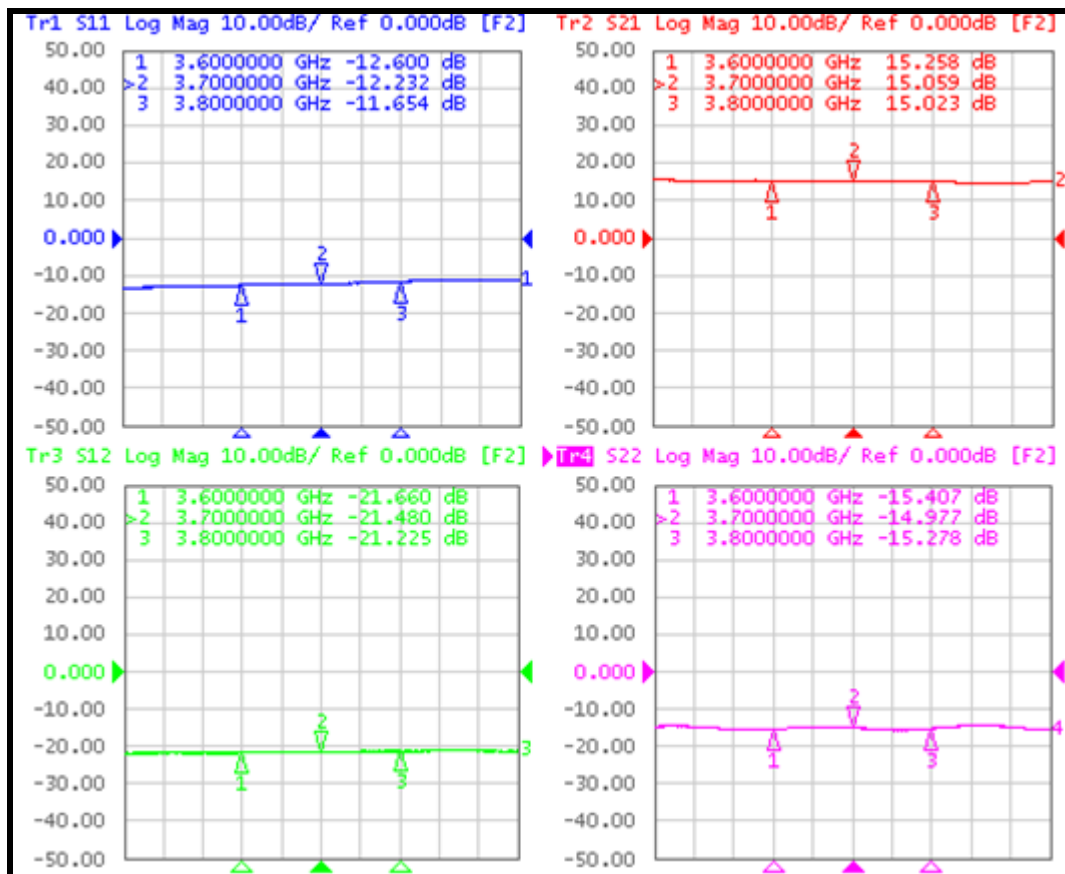

2.2 LTE_20MHz_ACLR Test Result

Out Power : -4.1 dBm

LTE_FDD_20MHz_TM 3p1_100% : 3700MHz -50dBc

