

RF MMIC Innovator

www.berex.com

[CLASSIFICATION] APPLICATION NOTE

[DATE] 2024. 07

[REVISION NO.] REV.B

[MEASURING INSTRUMENTS]

- NA_AGILENT E5071B

- SA_AGILENT N9020A

- SG_AGILENT 4438C

- SG_IFR 3416

Si-Ge Gain Block Amp BGS3

Application Note



Contents

RF MMIC INNOVATOR WWW.BEREX.COM 1

1. 3500MHZ APPLICATION3

 1.1 3500MHZ TEST RESULT(S-PARAMETER, OIP3, P1, NF,ACLR)4

 1.2 3500MHZ LTE_20MHZ_ACLR TEST RESULT5

2. 3700MHZ APPLICATION6

 2.1 3700MHZ TEST RESULT(S-PARAMETER, OIP3, P1, NF,ACLR)7

 2.2 3700MHZ LTE_20MHZ_ACLR TEST RESULT8

1. BGS3_ 3500MHz Application Note

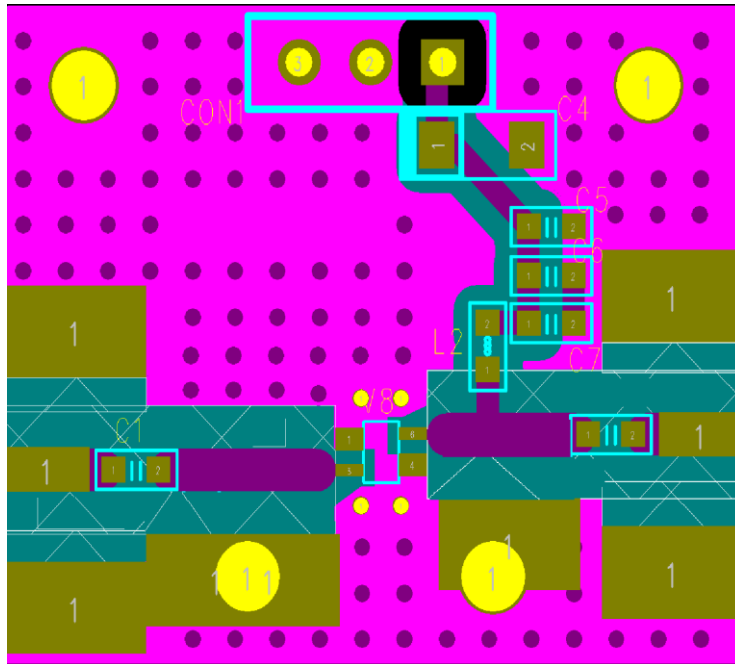

Ref. Des.	Description/ Part Number	Values	Vendor
C1	0603 CAP	10pF	Samsung
C2	0603 CAP	10pF	Samsung
C3	0603 CAP	100pF	Samsung
C4	0603 CAP	1000pF	Samsung
C5	A3216 CAP	10uF	AVX
L1	0603 CAP	12nH	Samsung
U1	SOT363 PKG	BGS3	BEREX

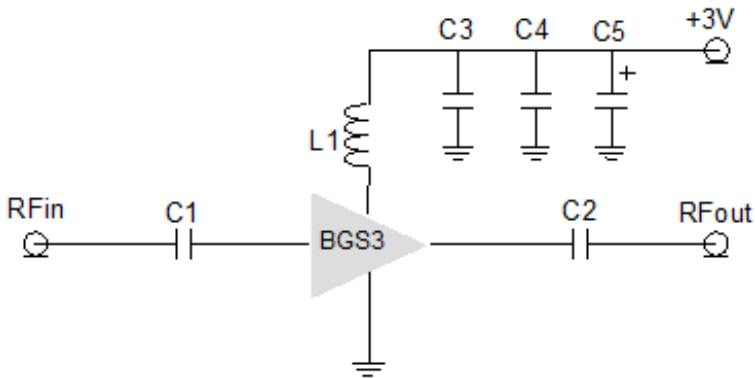

Note:

1. PCB: 31mil thick FR4

TITLE	
BGS3 Evaluation Board	
(3500MHz)	
Drawing Number	Rev.
Date	Drawn By
FILE NAME	SHEET

1.1 BGS3_3500MHz Test Result

SN	Freq [MHz]	Vcc [V]	Icc [mA]	Gain [dB]	OIP3 [dBm] ⁽¹⁾	P1dB [dBm]	IRL [dB]	ORL [dB]	NF [dB]
-	3400	3.0	53	18.3	27.4	14.8	-14.7	-19.1	1.9
-	3500	3.0	53	18.1	27.3	14.5	-14.4	-18.6	1.9
-	3600	3.0	53	18.0	27.2	14.4	-13.8	-20.6	2.0

(1) OIP3 was tested @Pout=0dBm/tone 1MHz offset

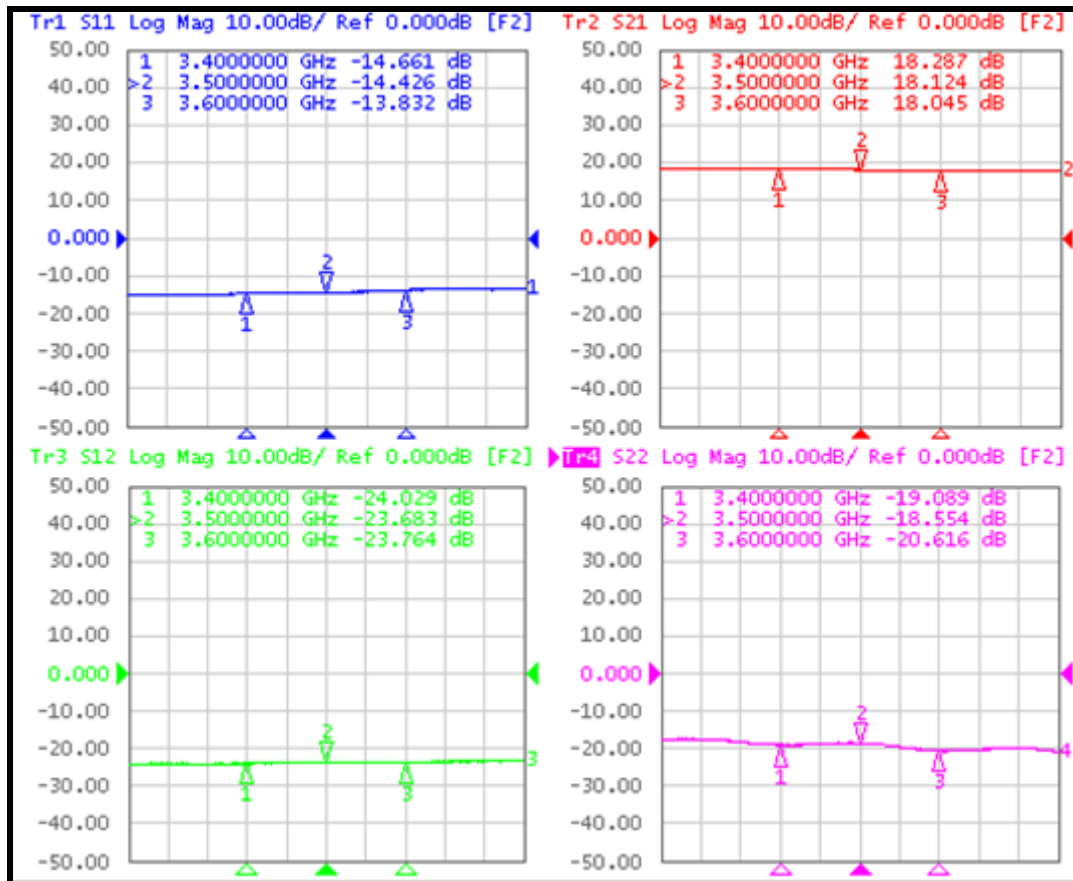

1.2 LTE_20MHz_ACLR Test Result

Out Power : 3.5 dBm

LTE_FDD_20MHz_TM 3p1_100% : 3500MHz -50dBc

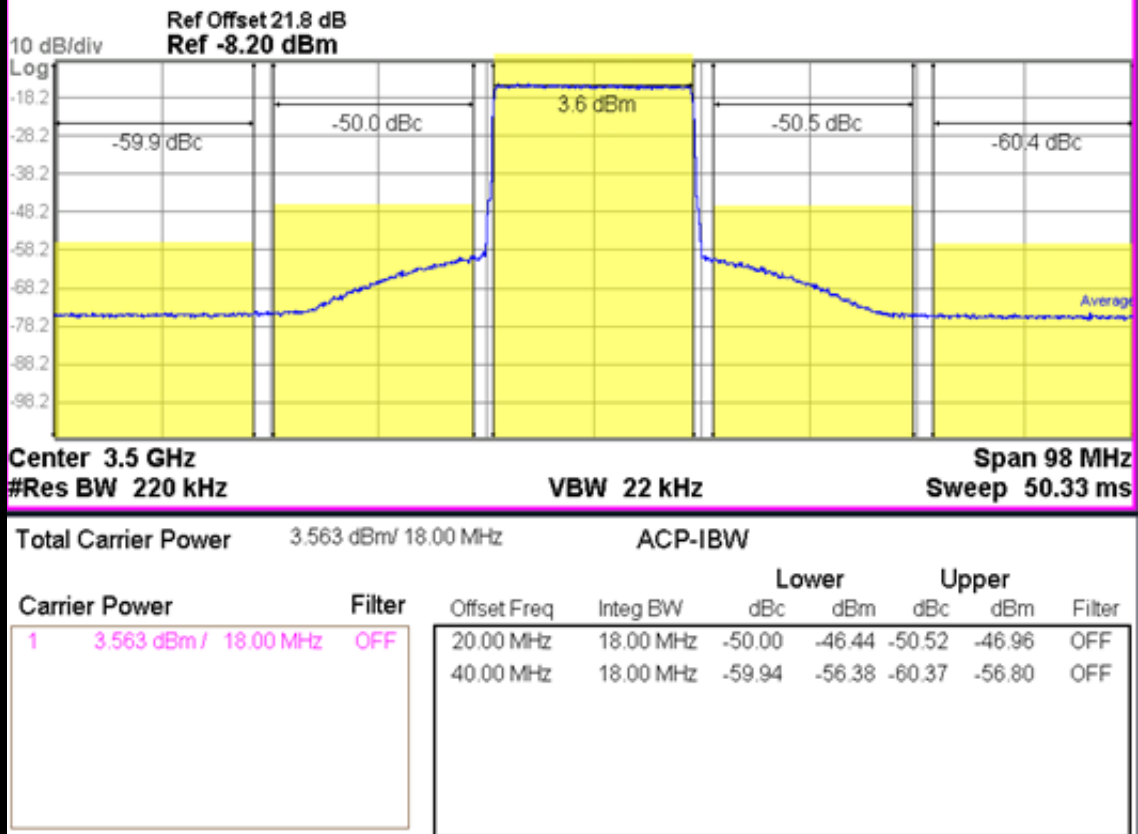

2. BGS3_ 3700MHz Application Note

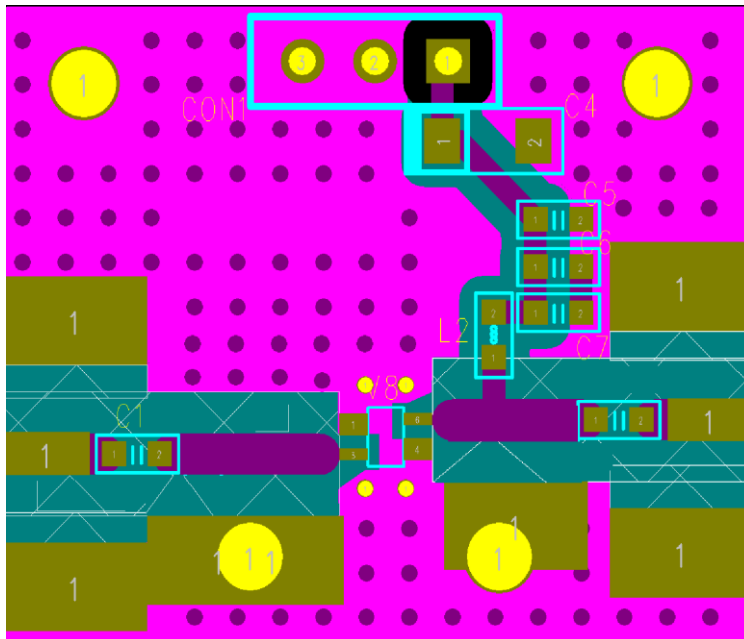

Ref. Des.	Description/ Part Number	Values	Vendor
C1	0603 CAP	10pF	Samsung
C2	0603 CAP	10pF	Samsung
C3	0603 CAP	100pF	Samsung
C4	0603 CAP	1000pF	Samsung
C5	A3216 CAP	10uF	AVX
L1	0603 CAP	12nH	Samsung
U1	SOT363 PKG	BGS3	BEREX

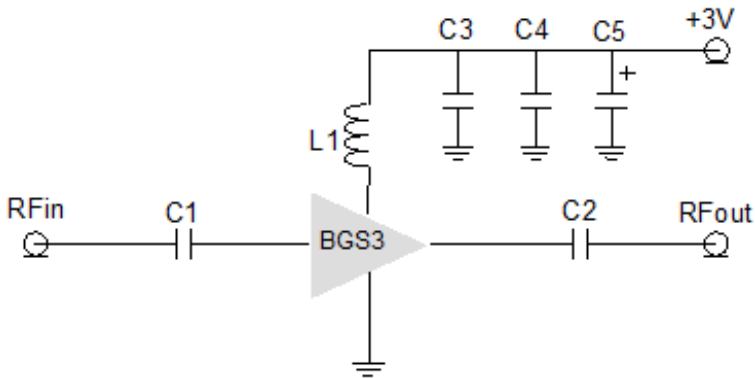

Note:

1. PCB: 31mil thick FR4

TITLE	
BGS3 Evaluation Board	
(3700MHz)	
Drawing Number	Rev.
Date	Drawn By
FILE NAME	SHEET

2.1 BGS3_3700MHz Test Result

SN	Freq [MHz]	Vcc [V]	Icc [mA]	Gain [dB]	OIP3 [dBm] ⁽¹⁾	P1dB [dBm]	IRL [dB]	ORL [dB]	NF [dB]
-	3600	3.0	53	18.0	27.2	14.4	-13.8	-20.6	2.0
-	3700	3.0	53	17.8	27.0	14.2	-13.6	-19.7	2.0
-	3800	3.0	53	17.7	26.9	14.0	-13.1	-22.8	2.2

(1) OIP3 was tested @Pout=0dBm/tone 1MHz offset

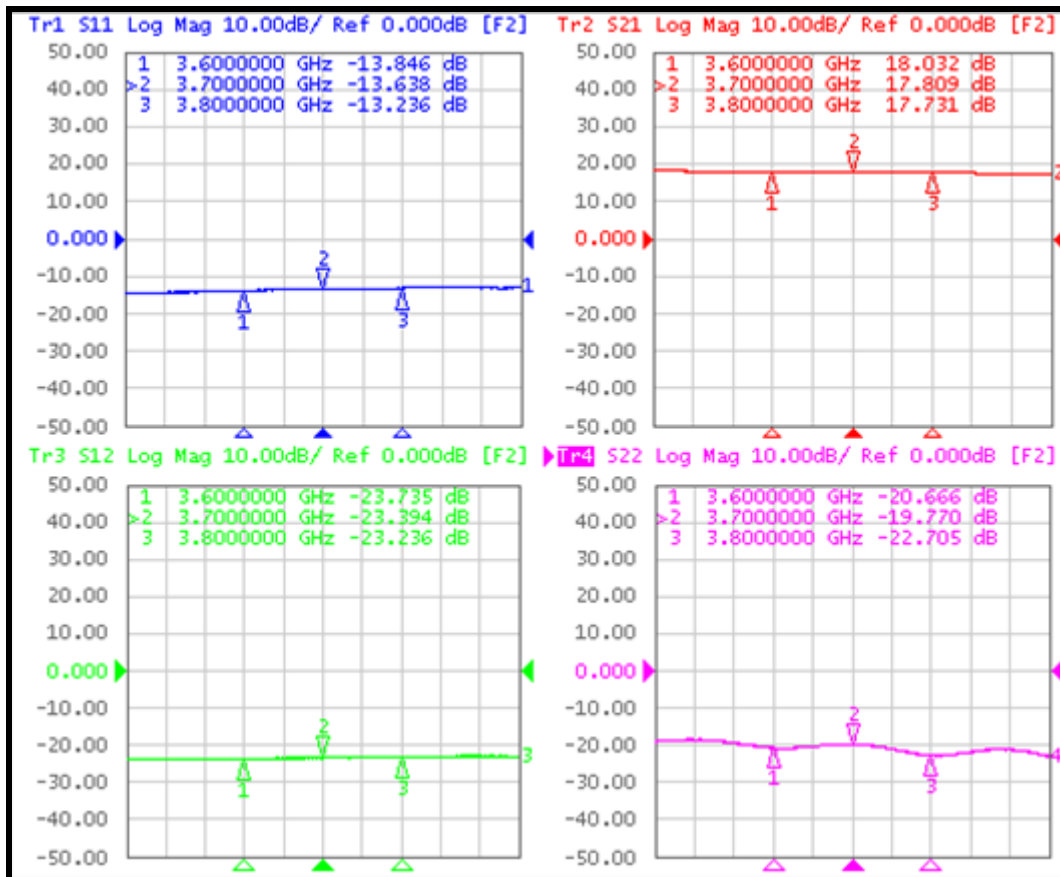

2.2 LTE_20MHz_ACLR Test Result

Out Power : 3.1 dBm

LTE_FDD_20MHz_TM 3p1_100% : 3700MHz -50dBc

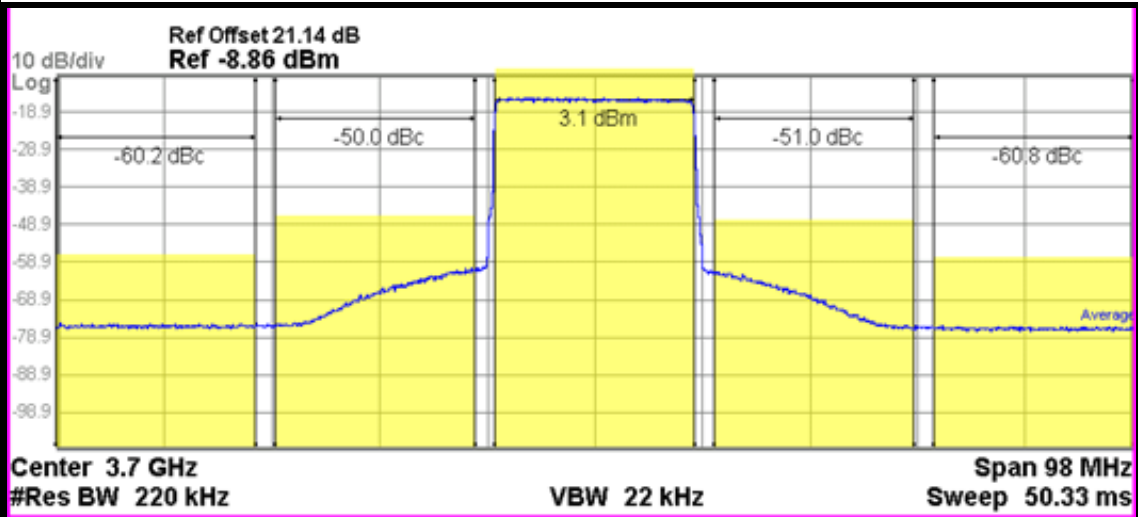

Carrier Power		Filter	ACP-IBW						
Offset Freq	Integ BW		Lower		Upper		Filter		
			dBc	dBm	dBc	dBm			
1	3.149 dBm / 18.00 MHz	OFF	20.00 MHz	18.00 MHz	-50.00	-46.85	-51.03	-47.89	OFF
			40.00 MHz	18.00 MHz	-60.20	-57.05	-60.82	-57.67	OFF

