

RF MMIC Innovator

[www.berex.com](http://www.berex.com)

[CLASSIFICATION] APPLICATION NOTE

[DATE] 2015. 01

[REVISION NO.] REV.A

[MEASURING INSTRUMENTS]

- NA\_AGILENT E5071B

- SA\_AGILENT N9020A

- SG\_AGILENT 4438C

- SG\_IFR 3416

## Si-Ge Gain Block Amp BGS5

### Application Note



**Contents**

RF RF MMIC INNOVATOR [WWW.BEREX.COM](http://WWW.BEREX.COM)..... 1

1. 3500MHZ APPLICATION .....3

    1.1 3500MHZ TEST RESULT(S-PARAMETER, OIP3, P1, NF,ACLR) ..... 4

    1.2 3500MHZ LTE\_20MHZ\_ACLR TEST RESULT .....5

2. 3700MHZ APPLICATION ..... 6

    2.1 3700MHZ TEST RESULT(S-PARAMETER, OIP3, P1, NF,ACLR) ..... 7

    2.2 3700MHZ LTE\_20MHZ\_ACLR TEST RESULT .....8

1. BGS5\_ 3500MHz Application Note

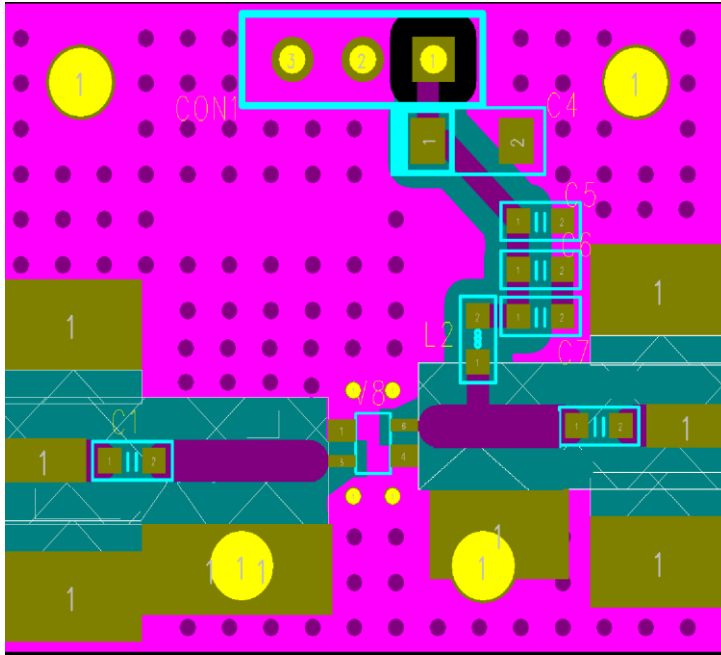

Ref. Des.	Description/ Part Number	Values	Vendor
C1	0603 CAP	10pF	Samsung
C2	0603 CAP	10pF	Samsung
C3	0603 CAP	100pF	Samsung
C4	0603 CAP	1000pF	Samsung
C5	A3216 CAP	10uF	AVX
L1	0603 CAP	12nH	Samsung
U1	SOT363 PKG	BGS5	BEREX

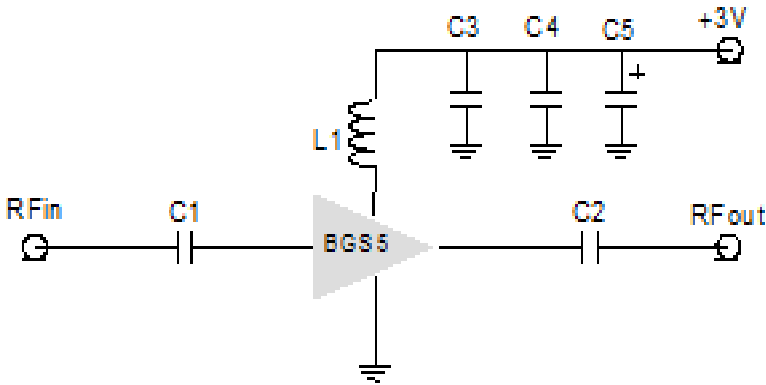

Note:

1. PCB: 31mil thick FR4

TITLE	
BGS5 Evaluation Board	
(3500MHz)	
Drawing Number	Rev.
Date	Drawn By
FILE NAME	SHEET

1.1 BGS5\_3500MHz Test Result

SN	Freq [MHz]	Vcc [V]	Icc [mA]	Gain [dB]	OIP3 [dBm] <sup>(1)</sup>	P1dB [dBm]	IRL [dB]	ORL [dB]	NF [dB]
-	3400	3.0	53	13.4	25.4	13.9	-15.4	-16.7	2.7
-	3500	3.0	53	13.3	25.1	13.8	-15.1	-16.9	2.7
-	3600	3.0	53	13.3	25.1	13.8	-14.5	-17.3	2.8

OIP3 was tested @Pout=0dBm/tone 1MHz offset

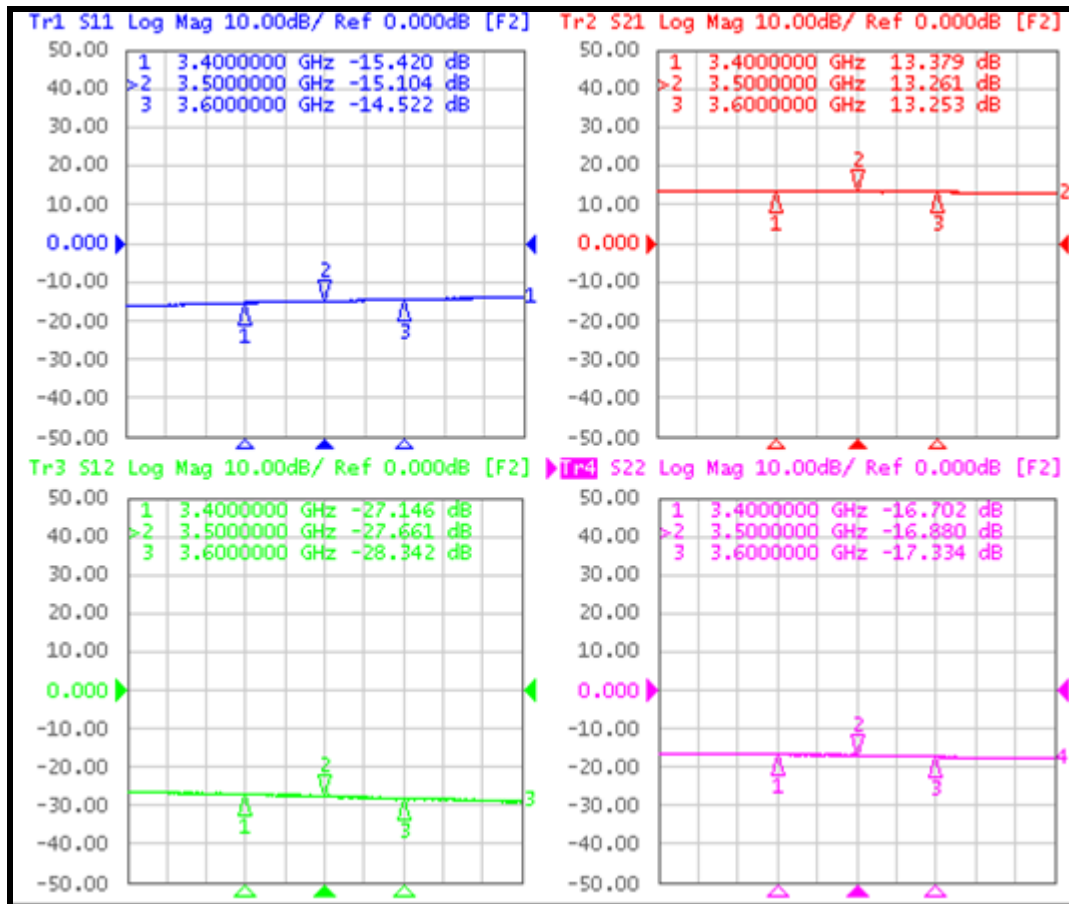

### 1.2 LTE\_20MHz\_ACLR Test Result

Out Power : 1.7 dBm

LTE\_FDD\_20MHz\_TM 3p1\_100% : 3500MHz -50dBc

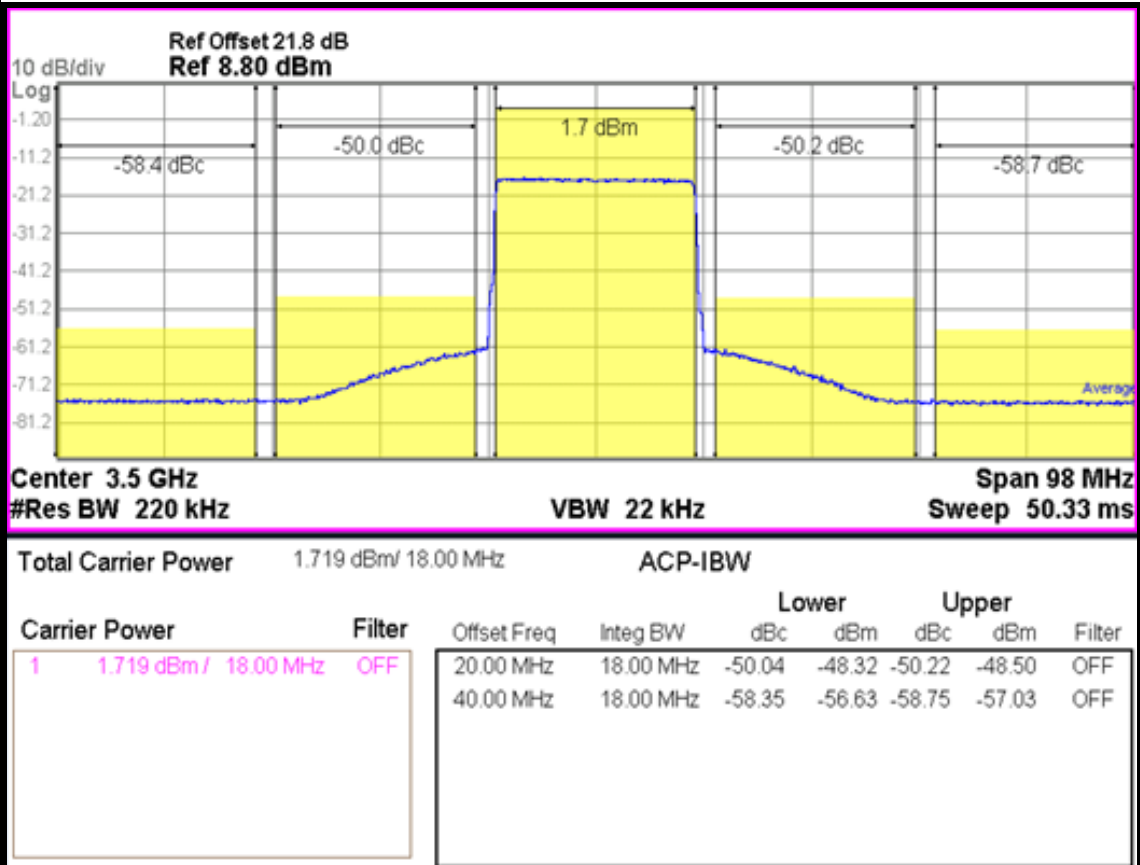

2. BGS5\_ 3700MHz Application Note

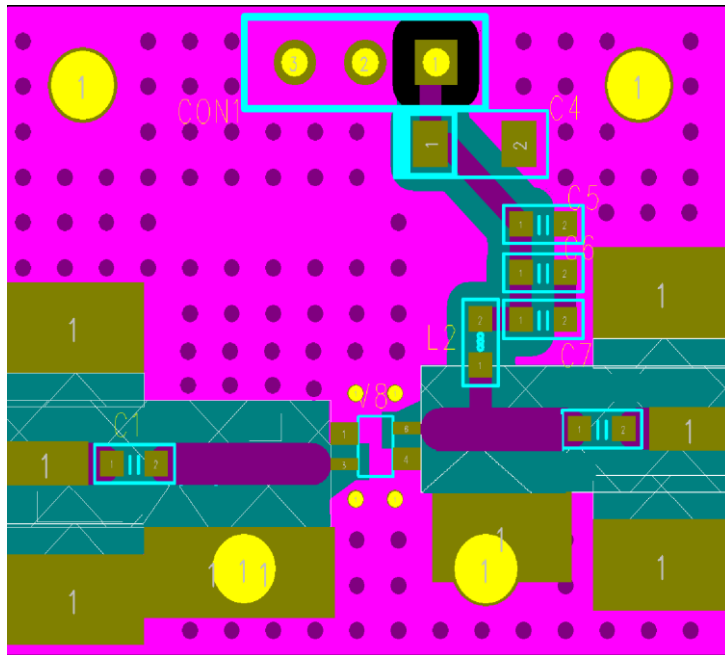

Ref. Des.	Description/ Part Number	Values	Vendor
C1	0603 CAP	10pF	Samsung
C2	0603 CAP	10pF	Samsung
C3	0603 CAP	100pF	Samsung
C4	0603 CAP	1000pF	Samsung
C5	A3216 CAP	10uF	AVX
L1	0603 CAP	12nH	Samsung
U1	SOT363 PKG	BGS5	BEREX

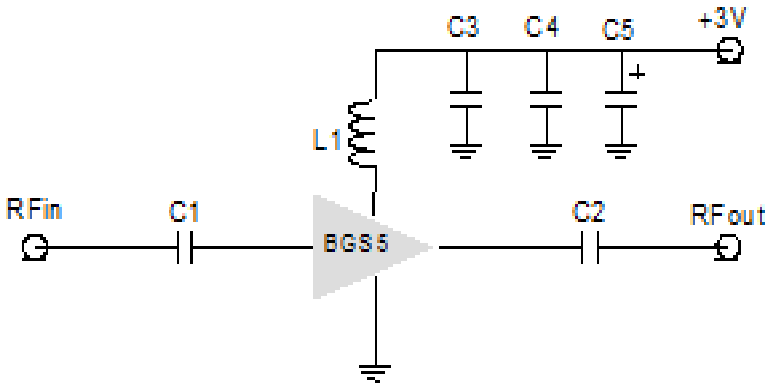

Note:

- 2. PCB: 31mil thick FR4

TITLE	
BGS5 Evaluation Board	
(3700MHz)	
Drawing Number	Rev.
Date	Drawn By
FILE NAME	SHEET

### 2.1 BGS5\_3700MHz Test Result

SN	Freq [MHz]	Vcc [V]	Icc [mA]	Gain [dB]	OIP3 [dBm] <sup>(1)</sup>	P1dB [dBm]	IRL [dB]	ORL [dB]	NF [dB]
-	3600	3.0	53	13.3	25.1	13.8	-15.8	-18.5	2.8
-	3700	3.0	53	13.1	25.0	13.5	-15.5	-18.1	2.8
-	3800	3.0	53	13.1	24.8	13.5	-14.9	-19.6	2.4

(1) OIP3 was tested @Pout=0dBm/tone 1MHz offset

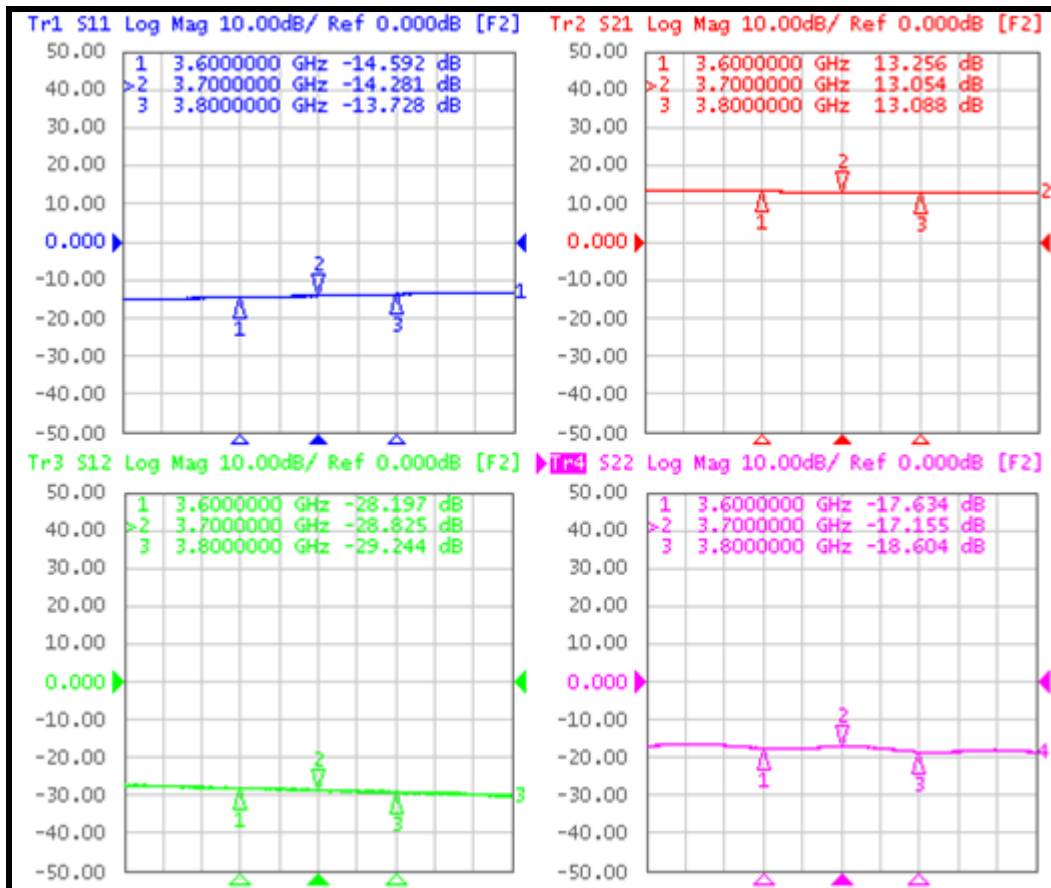

### 2.2 LTE\_20MHz\_ACLR Test Result

Out Power : 1.3 dBm

LTE\_FDD\_20MHz\_TM 3p1\_100% : 3700MHz -50dBc

