

1. RF MMIC Innovator

www.berex.com

[CLASSIFICATION] APPLICATION NOTE

[DATE] 2021.08

[REVISION NO.] REV.1.1

[MEASURING INSTRUMENTS]

- NA_AGILENT 8753ES

- SA_AGILENT E4440A

- SG_AGILENT 4438C

- SG_IFR 3416

High Power Amp BT33L

Application Note



Contents

RF MMIC INNOVATOR WWW.BEREX.COM 1

1. 100MHZ APPLICATION 3

 1.1 100MHZ TEST RESULT(S-PARAMETER, OIP3, P1, NF) 4

 1.2 100MHZ TEST RESULT(LTE 20MHZ ACLR)..... 5

2. 136~174MHZ APPLICATION 6

 2.1 136~174MHZ TEST RESULT(S-PARAMETER, OIP3, P1, NF) 7

 2.2 154MHZ TEST RESULT(LTE 20MHZ ACLR)..... 8

3. 170~220MHZ APPLICATION 9

 3.1 170~220MHZ TEST RESULT(S-PARAMETER, OIP3, P1, NF) 10

 3.2 195MHZ TEST RESULT(LTE 20MHZ ACLR)..... 11

1. BT33L_100MHz Application Note

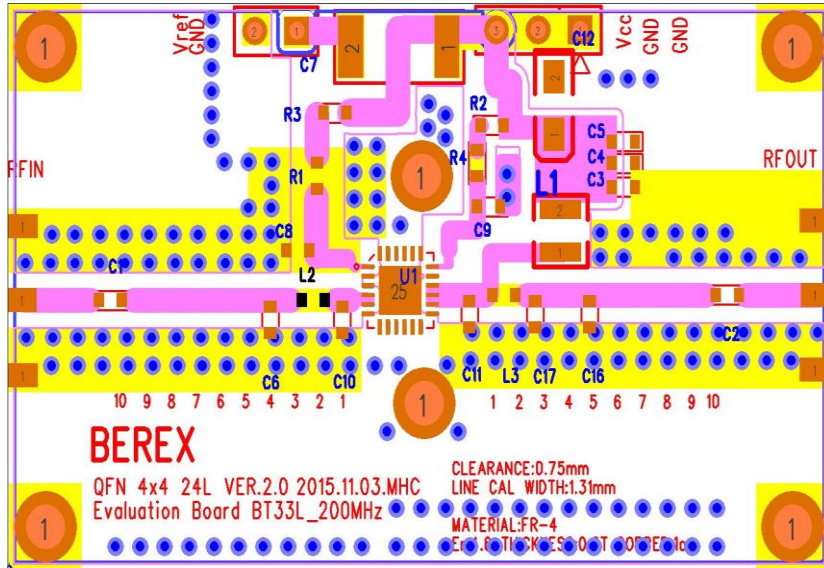

BOM			Marks
C1	603	22pF	Samsung
C2	603	100pF	Samsung
C3	603	22pF	Samsung
C4	603	1000pF	Samsung
C5	603	1 uF	Samsung
C6	603	39pF	Samsung
C7	603	N/C	
C8	603	N/C	
C9	603	N/C	
C10	603	N/C	
C11	603	27pF	Samsung
C12	603	N/C	
C16	603	N/C	
C17	603	33pF	Samsung
L1	1008	56nH	Coilcraft
L2	603	39nH	Taiyo Yuden
L3	603	39nH	Taiyo Yuden
R1	603	51Ω	Samsung
R2	603	91Ω	Samsung
R3	603	0Ω	Samsung
R4	603	0Ω	Samsung
U1	4x4	BT33L	BEREX

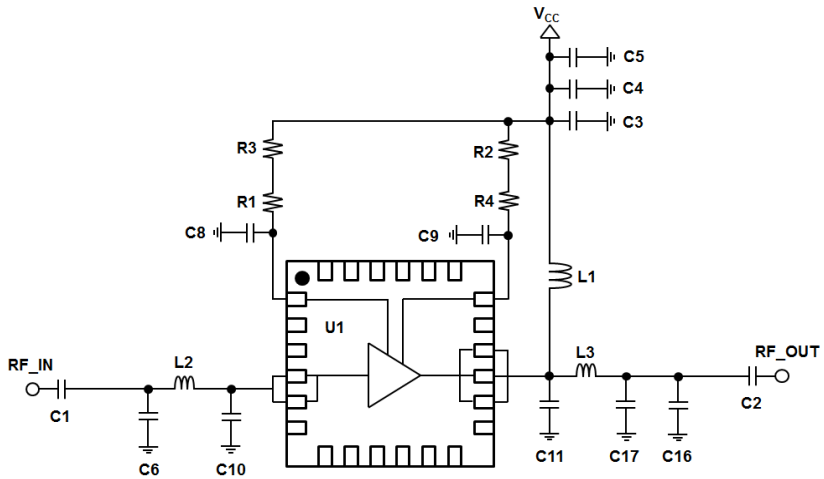

Note:

Reference	Object	Distance
Input pin	C6	5.5mm
Input pin	L2	2.5mm
Input pin	C10	1.3mm
Output pin	C11	1.8mm
Output pin	L3	3.4mm
Output pin	C17	7.8mm

TITLE	
BT33L Evaluation Board	
(100 MHz)	
Drawing Number	Rev.
Date	Drawn By
FILE NAME	SHEET

1.1 BT33L_100MHz Test Result

SN	Freq [MHz]	Vcc [V]	Icc [mA]	Gain [dB]	OIP3 [dBm] ⁽¹⁾	P1dB [dBm]	IRL [dB]	ORL [dB]	NF [dB]
	100	5	410	26.2	44.5	29.3	-10.6	-17.1	9.0

(1) OIP3 was tested @Pout=20dBm/tone 1MHz offset

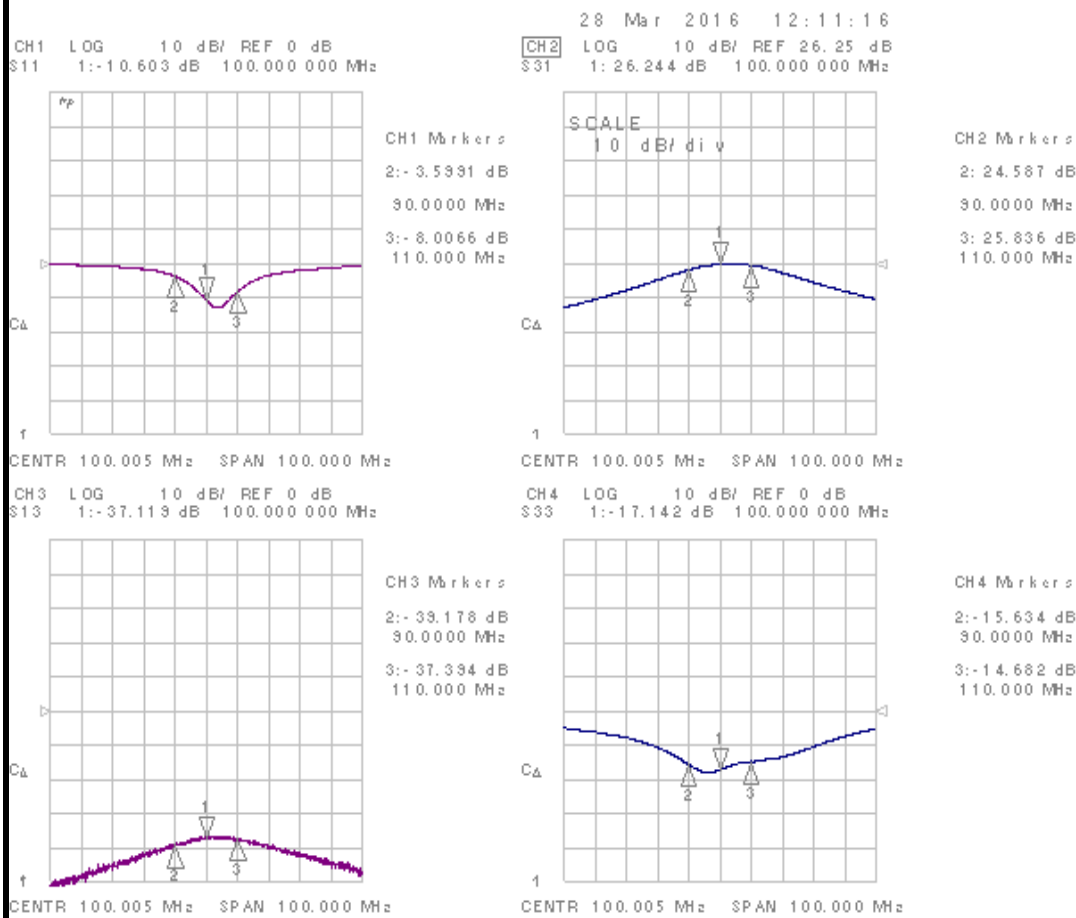

1.2 BT33L_ 100MHz LTE 20MHz ACLR

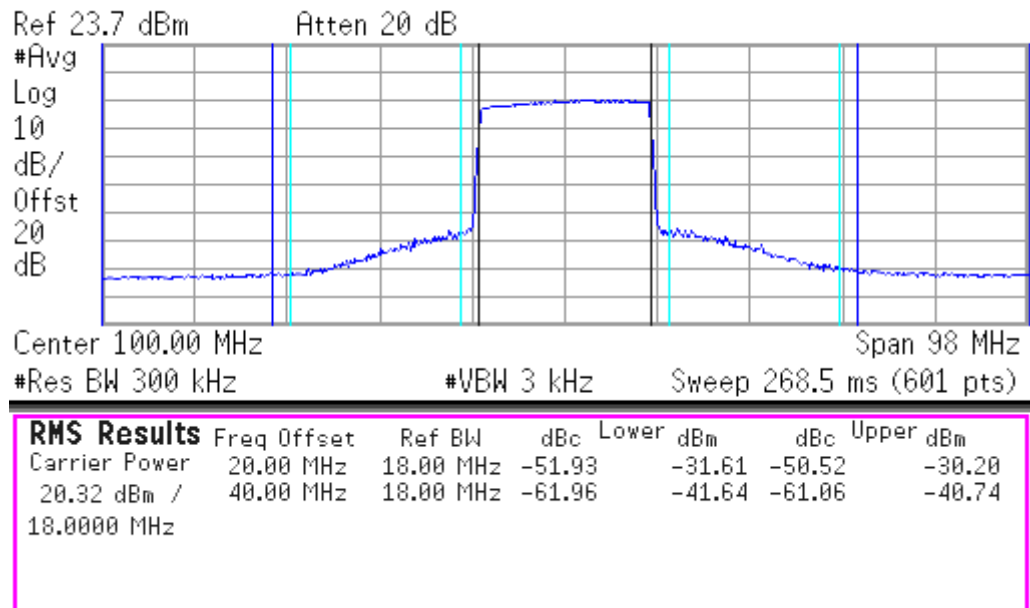

[Test condition]

⇒ -50dBc@Output power 20.32dBm

2. BT33L_136~170MHz Application Note

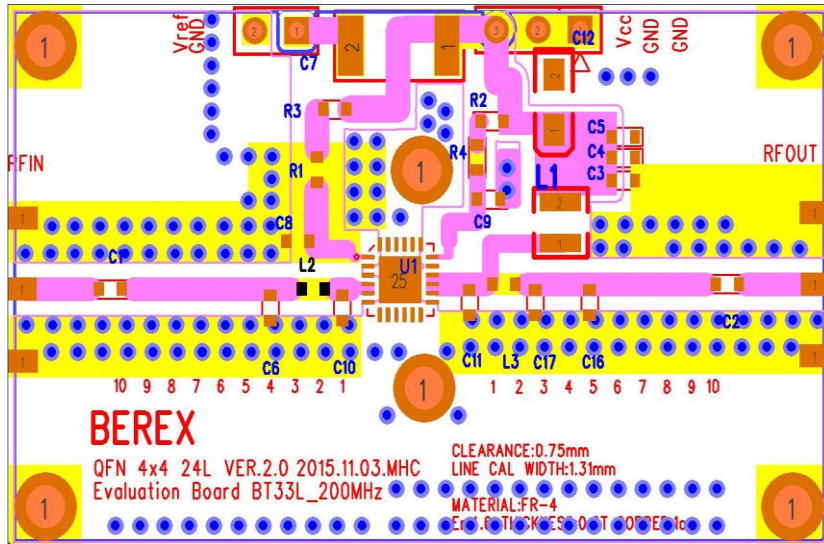

BOM			Marks
C1	603	22pF	Samsung
C2	603	100pF	Samsung
C3	603	22pF	Samsung
C4	603	1000pF	Samsung
C5	603	1 uF	Samsung
C6	603	39pF	Samsung
C7	603	N/C	
C8	603	N/C	
C9	603	N/C	
C10	603	N/C	
C11	603	27pF	Samsung
C12	603	N/C	
C16	603	N/C	
C17	603	33pF	Samsung
L1	1008	56nH	Coilcraft
L2	603	18nH	Taiyo Yuden
L3	603	27nH	Taiyo Yuden
R1	603	51Ω	Samsung
R2	603	91Ω	Samsung
R3	603	0Ω	Samsung
R4	603	0Ω	Samsung
U1	4x4	BT33L	BEREX

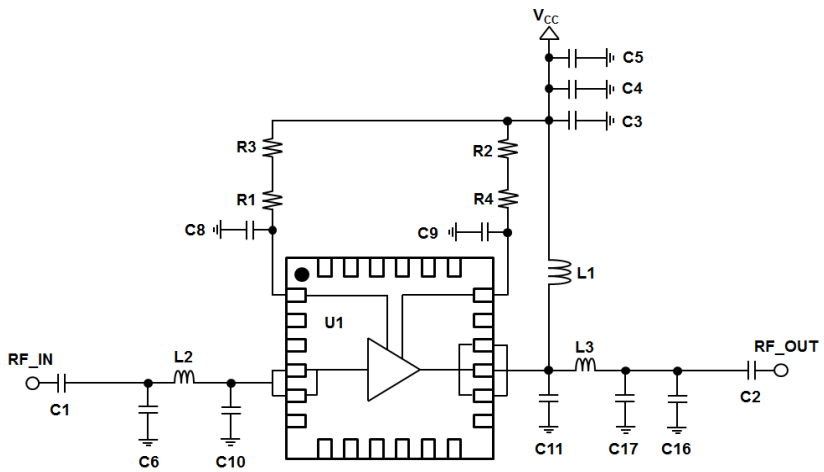

Note:

Reference	Object	Distance
Input pin	C6	5.5mm
Input pin	L2	2.5mm
Input pin	C10	1.3mm
Output pin	C11	2.0mm
Output pin	L3	3.4mm
Output pin	C17	10.5mm

TITLE	
BT33L Evaluation Board	
(136~170 MHz)	
Drawing Number	Rev.
Date	Drawn By
FILE NAME	SHEET

2.1 BT33L_136~170MHz Test Result

SN	Freq [MHz]	Vcc [V]	Icc [mA]	Gain [dB]	OIP3 [dBm] ⁽¹⁾	P1dB [dBm]	IRL [dB]	ORL [dB]	NF [dB]
	136	5	425	25.4	43.7	30.1	-5.4	-14.0	9.0
	154	5	425	26.5	44.0	30.7	-14.0	-13.4	9.0
	174	5	425	25.6	44.5	30.0	-5.6	-18.8	9.0

(1) OIP3 was tested @Pout=20dBm/tone 1MHz offset

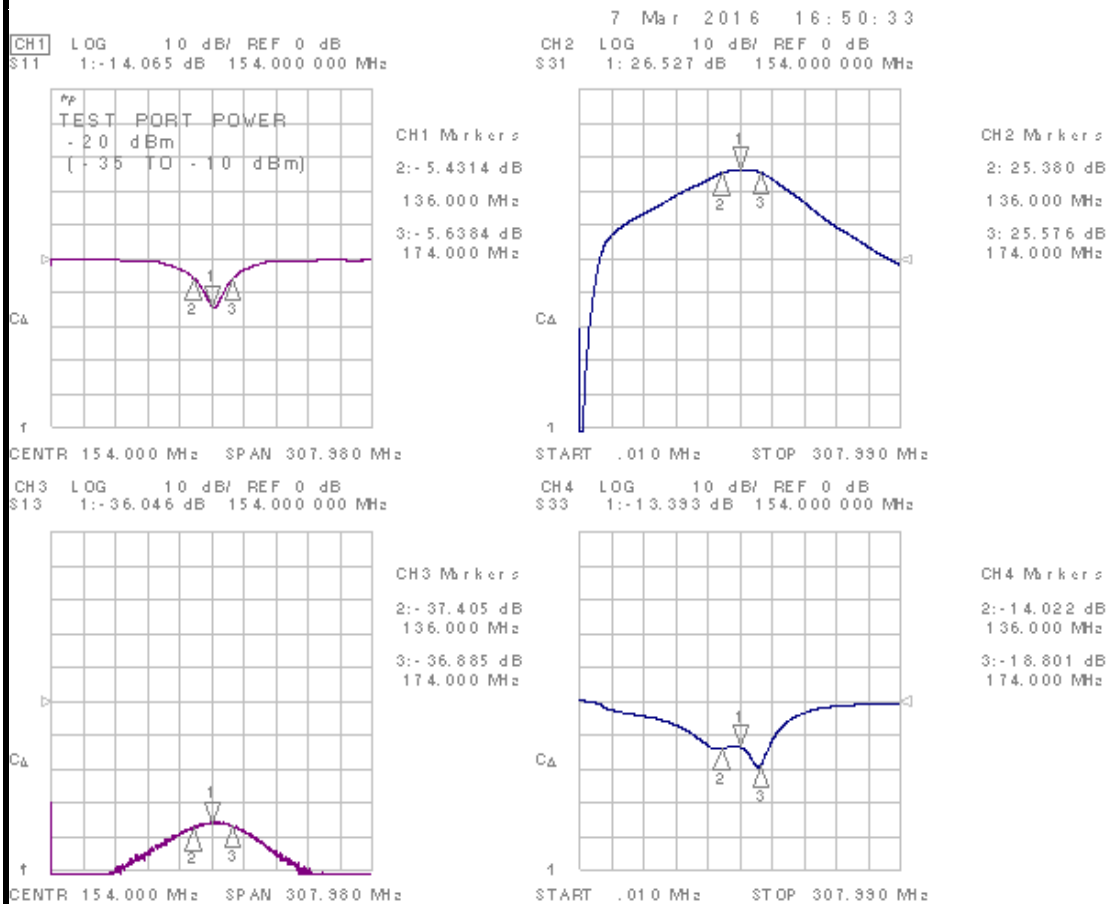

2.2 BT33L_ 100MHz LTE 20MHz ACLR

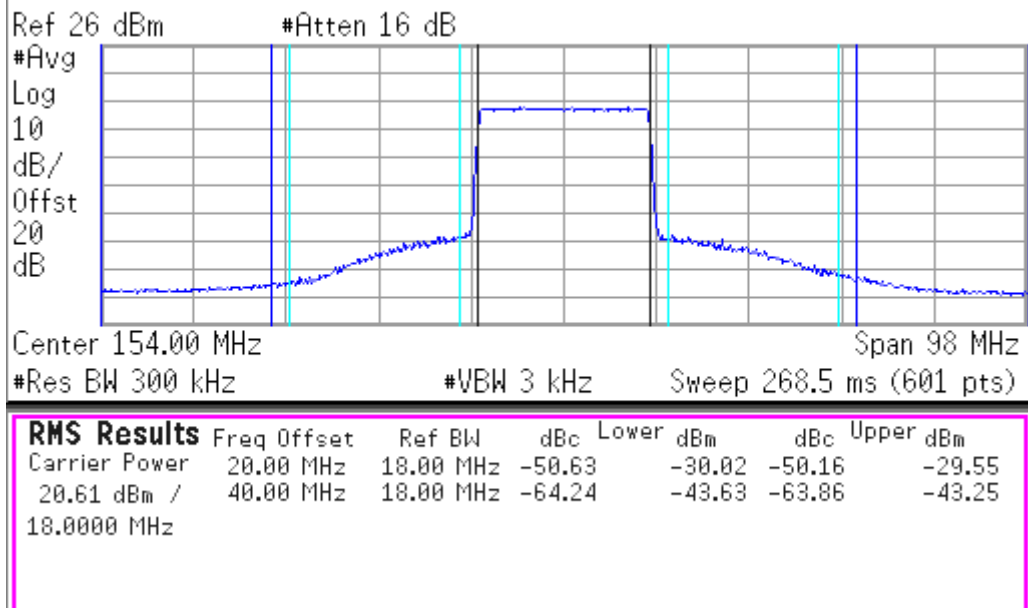

[Test condition]

⇒ -50dBc@Output power 20.61dBm

3. BT33L_170~220MHz Application Note

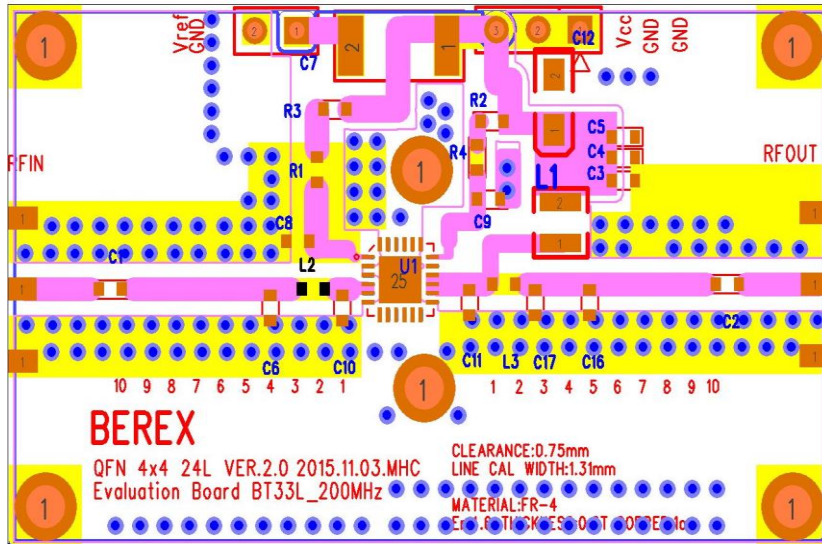

BOM			Marks
C1	603	22pF	Samsung
C2	603	100pF	Samsung
C3	603	22pF	Samsung
C4	603	1000pF	Samsung
C5	603	1 uF	Samsung
C6	603	39pF	Samsung
C7	603	N/C	
C8	603	N/C	
C9	603	N/C	
C10	603	N/C	
C11	603	27pF	Samsung
C12	603	N/C	
C16	603	N/C	
C17	603	33pF	Samsung
L1	1008	56nH	Coilcraft
L2	603	12nH	Taiyo Yuden
L3	603	15nH	Taiyo Yuden
R1	603	51Ω	Samsung
R2	603	91Ω	Samsung
R3	603	0Ω	Samsung
R4	603	0Ω	Samsung
U1	4x4	BT33L	BEREX

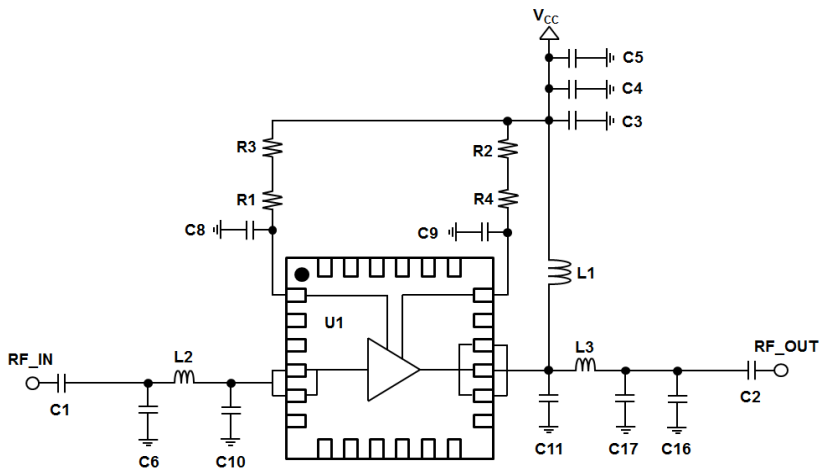

Note:

Reference	Object	Distance
Input pin	C6	5.5mm
Input pin	L2	2.5mm
Input pin	C10	1.3mm
Output pin	C11	2.0mm
Output pin	L3	3.4mm
Output pin	C17	10.5mm

TITLE	
BT33L Evaluation Board	
(170~220 MHz)	
Drawing Number	Rev.
Date	Drawn By
FILE NAME	SHEET

3.1 BT33L_170~220MHz Test Result

SN	Freq [MHz]	Vcc [V]	Icc [mA]	Gain [dB]	OIP3 [dBm] ⁽¹⁾	P1dB [dBm]	IRL [dB]	ORL [dB]	NF [dB]
	170	5	407	25.0	43.0	32.1	-7.0	-8.0	9.0
	195	5	407	26.3	42.3	32.4	-18.4	-9.1	9.0
	220	5	407	25.4	43.0	32.1	-6.0	-20.7	9.0

(1) OIP3 was tested @Pout=20dBm/tone 1MHz offset

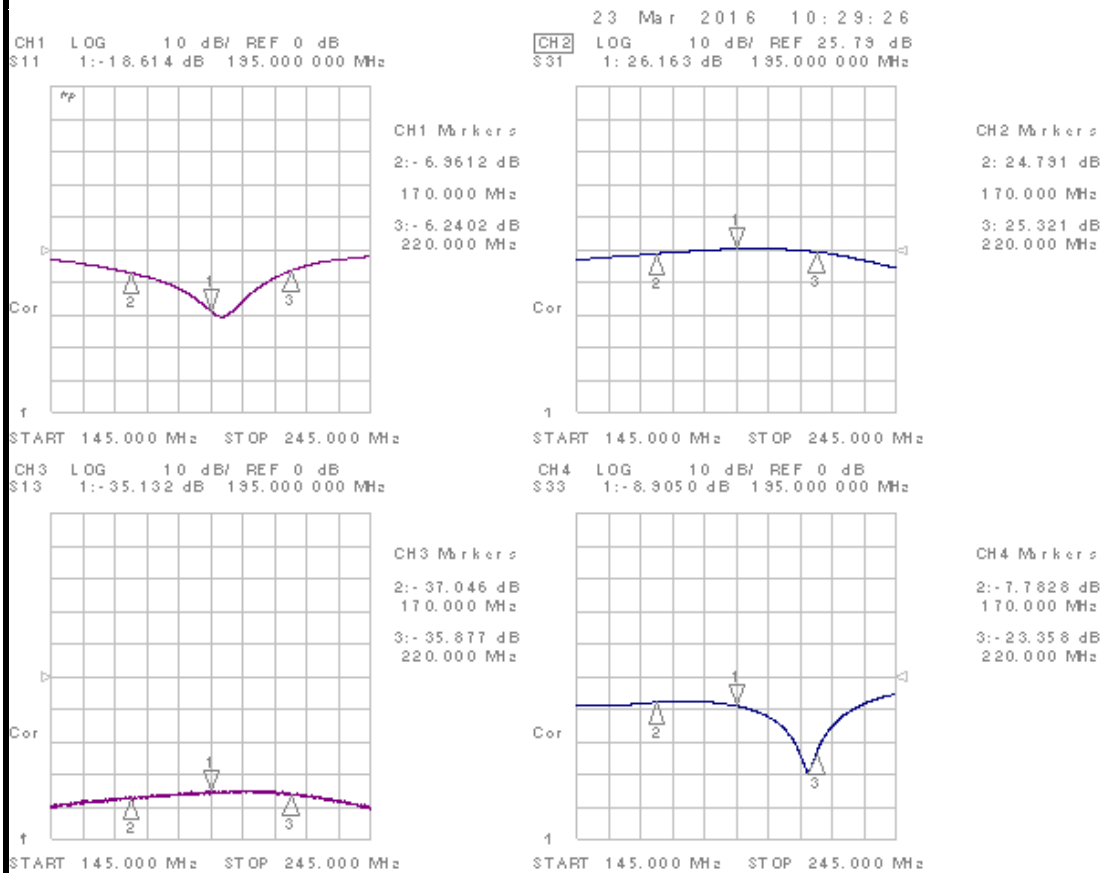

3.2 BT33L_ 100MHz LTE 20MHz ACLR

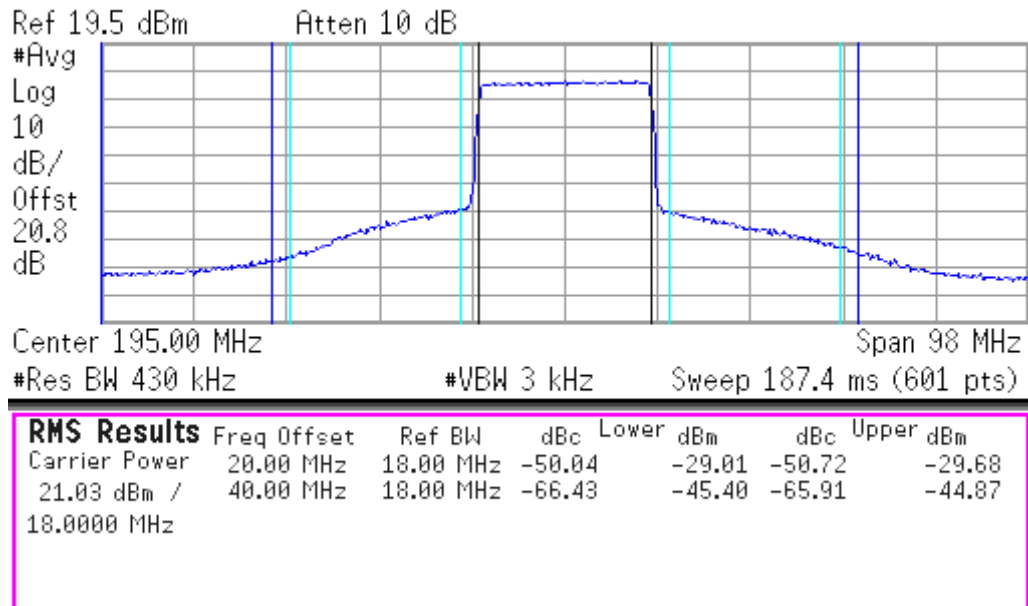

[Test condition]

⇒ -50dBc@Output power 21.03dBm