

### Device Features

- OIP3 = 43.0 dBm @ 70 MHz
- Gain = 17.5 dB @ 70 MHz
- Output P1 dB = 20.5 dBm @ 70 MHz
- Patented temperature compensation
- Patented over voltage protection
- RoHS2-compliant SOT-89 SMT package



### Product Description

BeRex's BIF5 is a high performance InGaP/GaAs HBT MMIC amplifier, internally matched to 50 Ohms and uses a patented **temperature compensation** circuit to provide stable current over the operating temperature range without the need for external components and a patented **over voltage protection** circuit to protect a internal device. The BIF5 is designed for high linearity IF amplifier that requires excellent gain, high OIP3 and flatness. It is packaged in a RoHS2-compliant with SOT-89 surface mount package.

### Applications

- Base station Infrastructure/RFID
- Commercial/Industrial/Military wireless system

### Applications Circuit

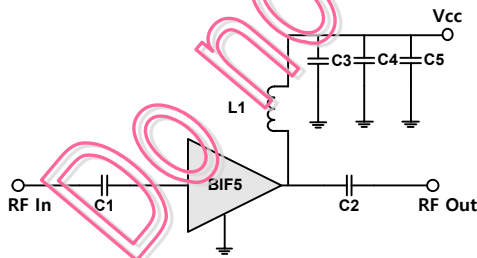

\*C1, C2=100nF ± 5%; C3 = 100 pF ± 5%; C4 = 1000pF ±5%

\*C5 = 10uF; L1 = 1uH ±5%

\*C1, C2 = 100pF; L1 = 33nH ±5% for RF Bandwidth

### Electrical Specifications

Device performance \_ measured on a BeRex evaluation board at 25°C, Vc=5V, 50 Ω system.

Parameter	Conditions	Min	Typ	Max	Unit
Operational Frequency Range		5		800	MHz
Test Frequency			70		MHz
Gain		16.0	17.5		dB
Input Return Loss			-15.8		dB
Output Return Loss			-17.1		dB
Output IP3	10 dBm / tone , Δf=1 MHz	40.0	43.0		dBm
Output P1dB		19.5	20.5		dBm
Noise Figure			4.0		dB

### Recommended Operating Conditions

Parameter	Min	Typ	Max	Unit
Bandwidth	5		800	MHz
I <sub>c</sub> @ (V <sub>c</sub> = 5V)	86	107	128	mA
V <sub>c</sub>	3.5	5.0	5.25	V
dG/dT		-0.003		dB/°C
R <sub>TH</sub>		50		°C/W
Operating Case Temperature	-40		+85	°C

Electrical specifications are measured at specified test conditions.

Specifications are not guaranteed over all recommended operating conditions.

### Absolute Maximum Ratings

Parameter	Rating	Unit
Storage Temperature	-55 to +155	°C
Junction Temperature	+180	°C
Supply Voltage	+6.0	V
Supply Current	160	mA
Input RF Power	23	dBm

Operation of this device above any of these parameters may result in permanent damage.

Above 7V, a device goes to protection mode.

## 5-800 MHz Internally Matched IF Amplifier

Typical Performance (Vd = 5V, Ic = 107mA, T = 25°C)

Freq	MHz	70	140	250	500	800
S21	dB	17.5	17.5	17.5	17.5	17.1
S11	dB	-15.8	-15.4	-15.5	-14.1	-18.3
S22	dB	-17.1	-19.1	-26.3	-16.1	-10.8
P1	dBm	20.5	20.5	20.5	21.0	21
OIP3	dBm	43	42.5	41.0	40.0	37
NF	dB	4.0	4.1	4.2	4.3	4.3

Typical Performance (Vd = 4.7V, Ic = 95mA, T = 25°C)

Freq	MHz	70	140	250	500	800
S21	dB	17.6	17.5	17.4	17.4	17.1
S11	dB	-15.1	-17.3	-18.1	-17.5	-18.7
S22	dB	-14.3	-13.7	-14.1	-14	-10.7
P1	dBm	19.6	20.2	20.1	20.4	20
OIP3	dBm	41	40.5	39.5	37	35.5
NF	dB	4.0	4.1	4.2	4.3	4.3

Typical Performance (Vd = 4.5V, Ic = 85mA, T = 25°C)

Freq	MHz	70	140	250	500	800
S21	dB	17.4	17.4	17.5	17.4	17
S11	dB	-15.3	-17.6	-18.3	-17.8	-18.9
S22	dB	-14.2	-13.5	-13.9	-13.9	-10.6
P1	dBm	19.2	19.0	19.2	19.4	19.4
OIP3	dBm	40.0	41.0	38.5	36.5	35
NF	dB	4.0	4.1	4.2	4.3	4.3

Typical Performance (Vd = 4V, Ic = 63mA, T = 25°C)

Freq	MHz	70	140	250	500	800
S21	dB	17.4	17.3	17.2	17.2	16.9
S11	dB	-16	-18.6	-19.5	-18.9	-20.1
S22	dB	-13.8	-13.1	-13.5	-13.5	-10.3
P1	dBm	17	17.5	17.7	17.5	17.2
OIP3	dBm	35.5	35.5	35	33	32
NF	dB	4.0	4.1	4.2	4.3	4.3

Typical Performance (Vd = 3.5V, Ic = 41mA, T = 25°C)

Freq	MHz	70	140	250	500	800
S21	dB	17.1	17.0	16.9	16.8	16.5
S11	dB	-17.9	-21.2	-22.6	-21.7	-23.1
S22	dB	-13.1	-12.3	-12.6	-12.6	-9.8
P1	dBm	13.7	14.6	14.6	14.5	14.2
OIP3	dBm	29	29	29	27.5	27.5
NF	dB	4.0	4.1	4.2	4.3	4.3

### Typical Device Data

S-parameters (Vc=5V, Ic=107mA, T=25°C)

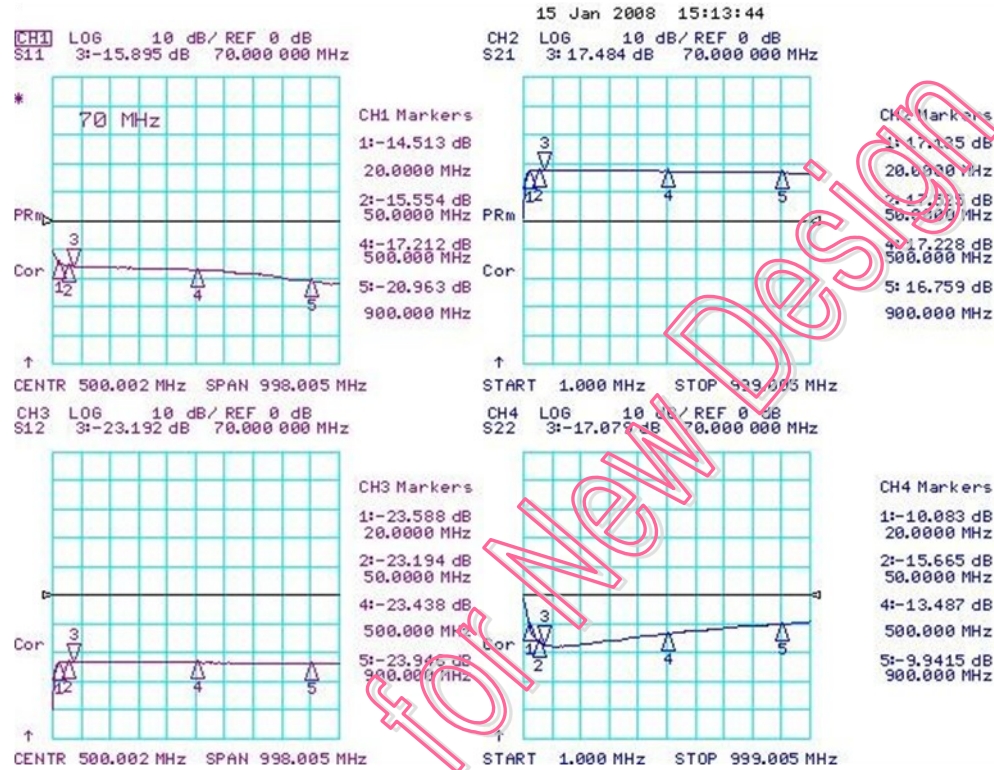

### S-Parameter

(Vdevice = 5.0V, Icc = 107mA, T = 25 °C, calibrated to device leads)

Freq	S11	S11	S21	S21	S12	S12	S22	S22
[MHz]	[Mag]	[Ang]	[Mag]	[Ang]	[Mag]	[Ang]	[Mag]	[Ang]
100	0.635	175.5	8.232	175.6	0.066	0.3	0.155	-12.0
500	0.627	157.0	7.315	159.7	0.072	-1.4	0.178	-62.9
1000	0.603	136.7	7.880	144.7	0.066	-1.8	0.235	-111.5
1500	0.580	118.0	6.733	131.1	0.070	2.4	0.322	-151.7
2000	0.491	99.4	6.895	114.4	0.069	-1.7	0.393	175.7
2500	0.471	86.3	6.953	104.4	0.071	5.1	0.470	147.9
3000	0.432	69.7	8.427	80.7	0.080	-0.9	0.549	119.3
3500	0.415	63.8	7.474	53.8	0.079	-0.9	0.608	97.8
4000	0.457	51.4	6.617	32.7	0.090	-8.8	0.640	68.7

### RF Bandwidth

S-parameters (Vc=5V, Ic=107mA, T=25°C)

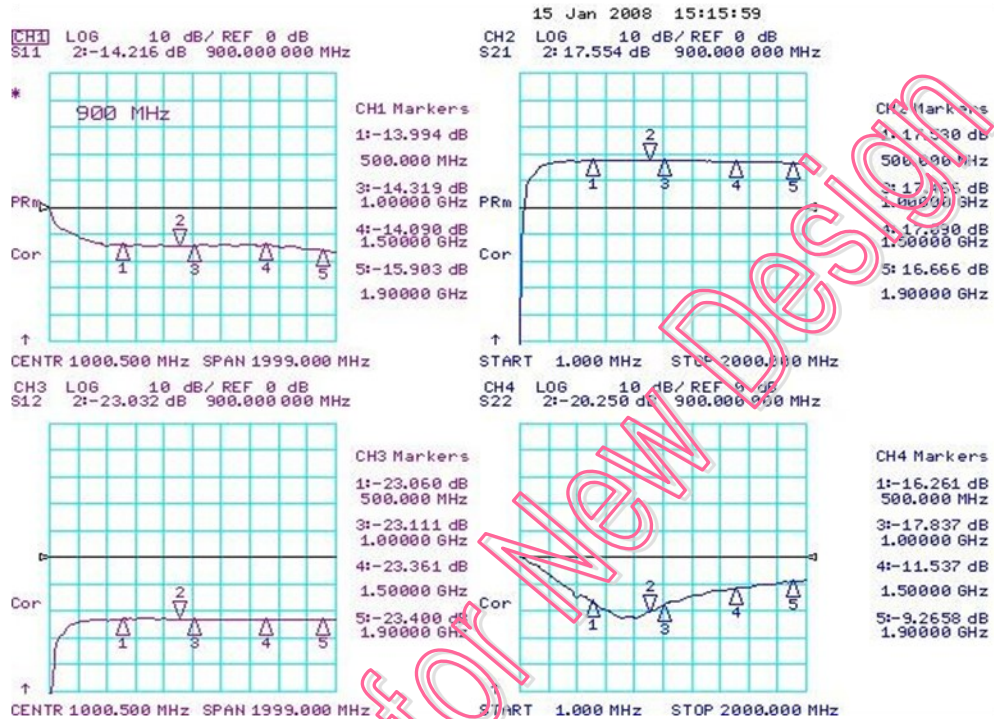

### V-I Characteristics

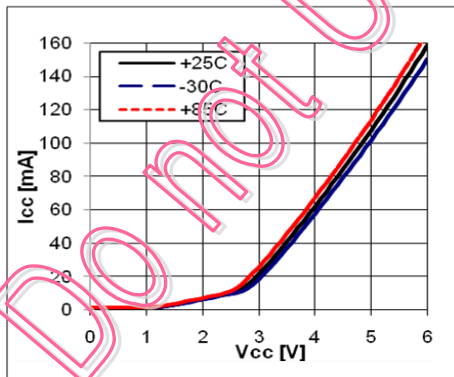

### BeRex SOT89 Evaluation Board

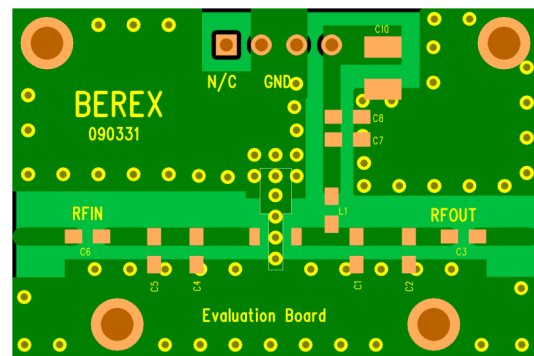

\*Dielectric constant \_ 4.2 \*RF pattern width 52mil \*31mil thick FR4 PCB

### Typical Performance

( $V_c=5V$ ,  $I_c=107mA$ ,  $T=25^\circ C$ )

#### Pin-Pout-Gain

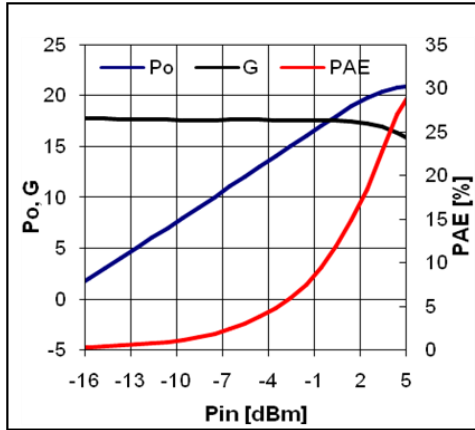

70MHz

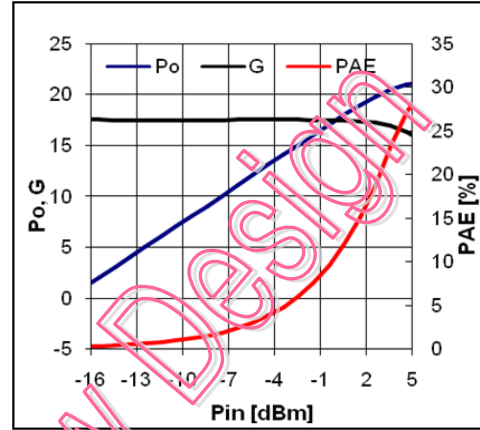

140MHz

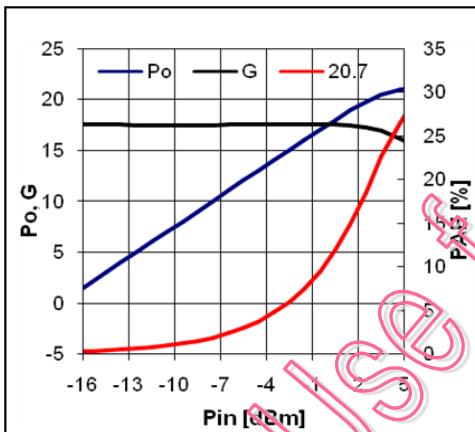

250MHz

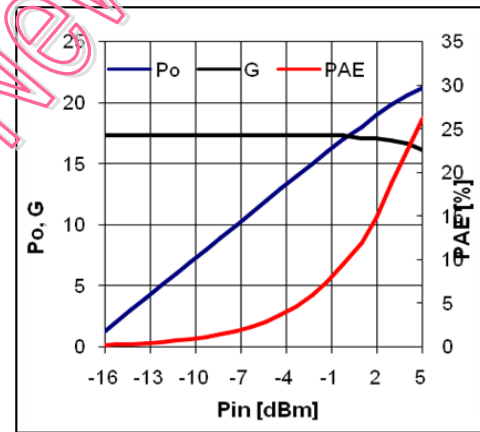

500MHz

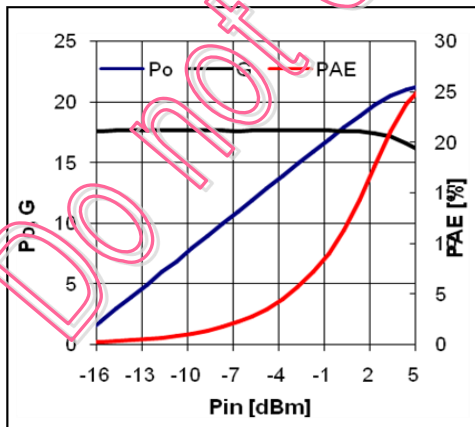

900MHz

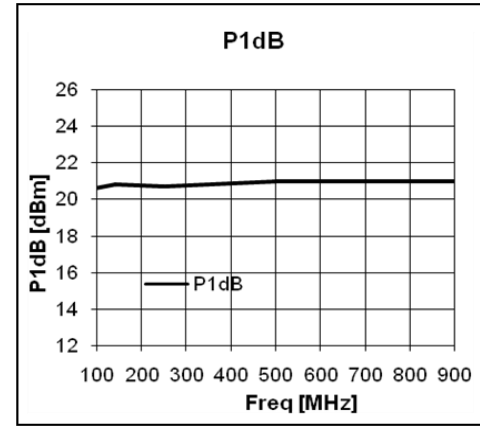

P1dB

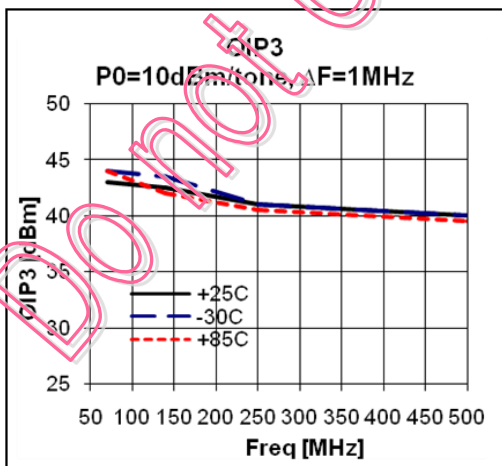
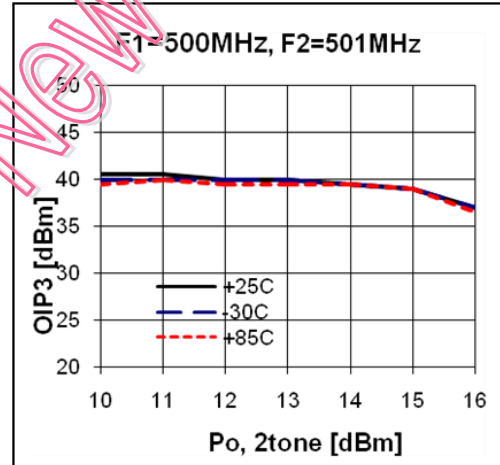
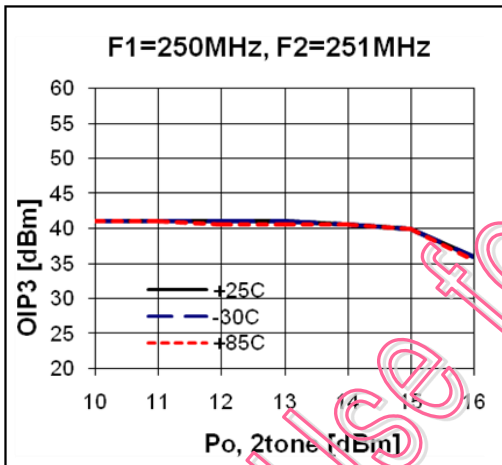
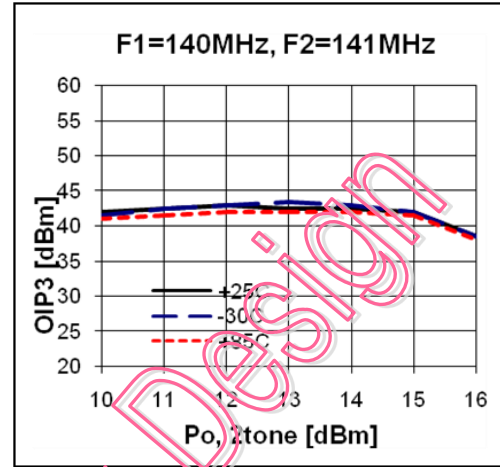
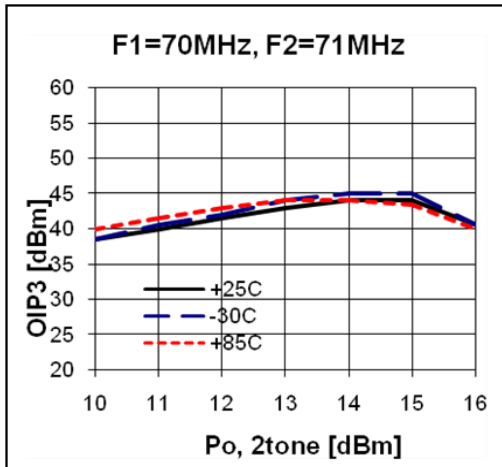
**OIP3**

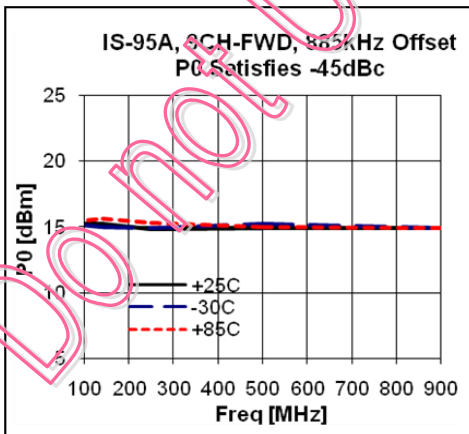
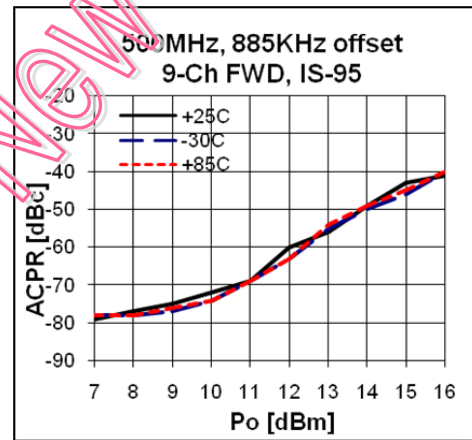
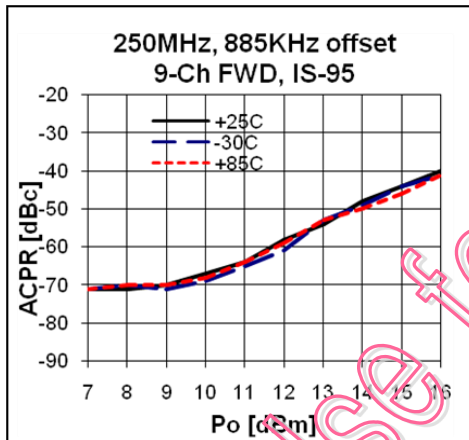
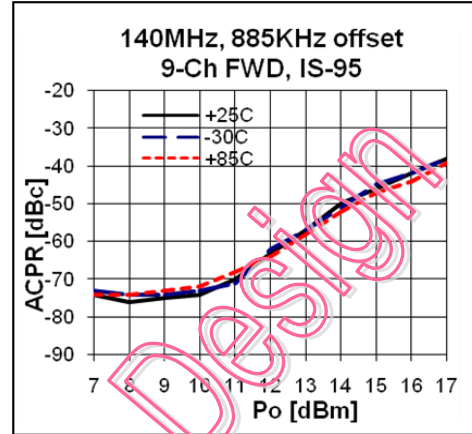
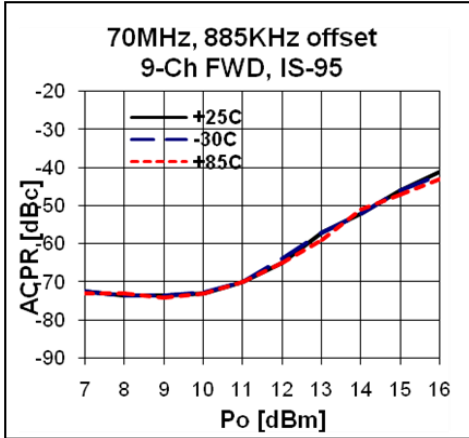
**ACPR**

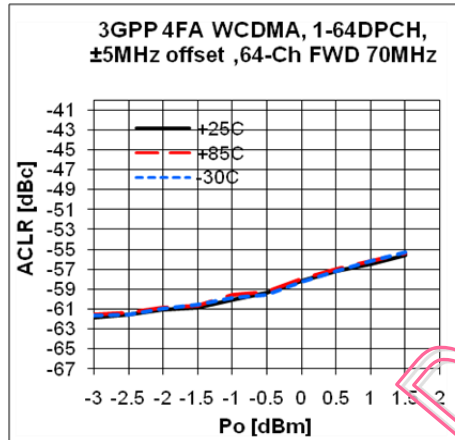
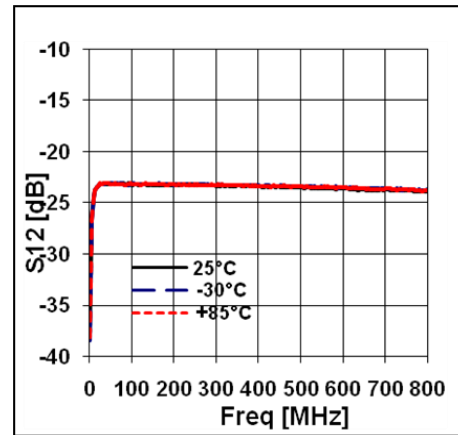
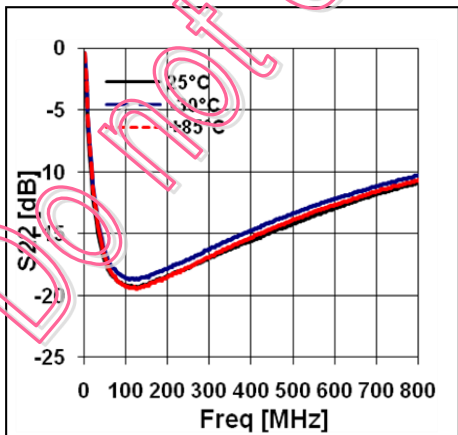
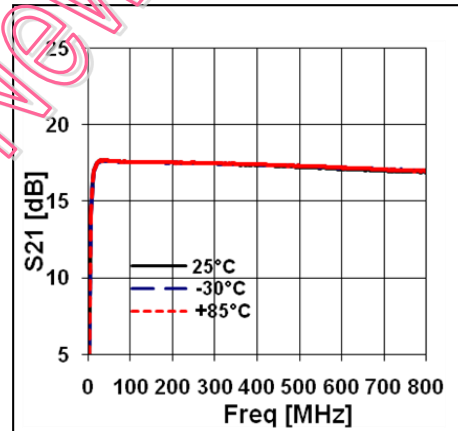
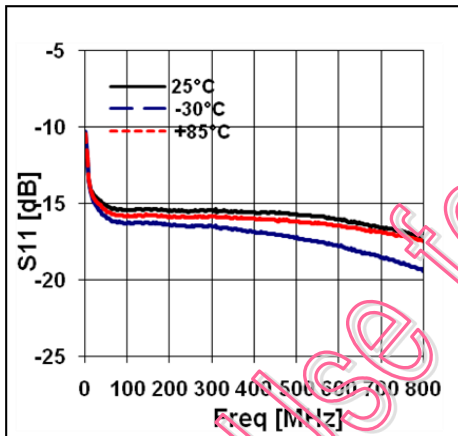
**ACLR**

**S-Parameters over Temperature**

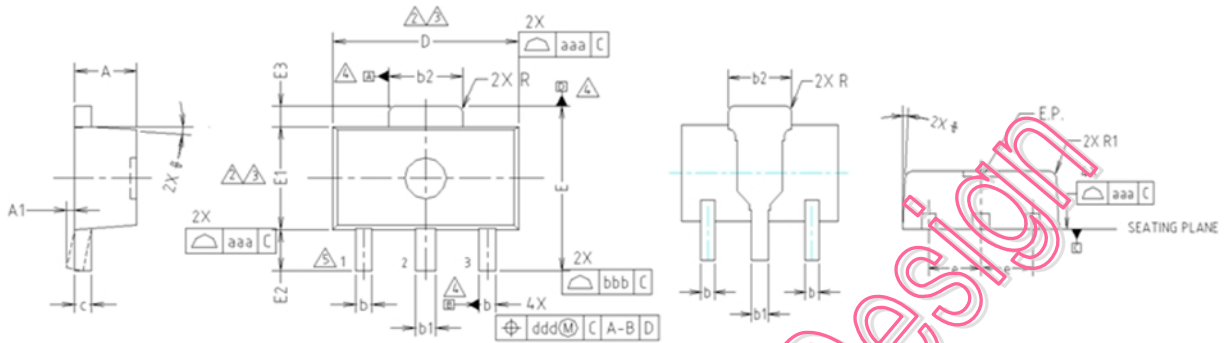
### Package Outline Dimension



- NOTE:**  
 1. DIMENSIONS IN MILLIMETERS.
- ⚠ DIMENSION D DOES NOT INCLUDE MOLD FLASH, PROTRUSIONS OR GATE BURRS. MOLD FLASH, PROTRUSIONS OR GATE BURRS SHALL NOT EXCEED 0.5mm PER END. DIMENSION E1 DOES NOT INCLUDE INTERLEAD FLASH OR PROTRUSION. INTERLEAD FLASH OR PROTRUSION SHALL NOT EXCEED 0.5mm PER SIDE.
  - ⚠ DIMENSIONS D AND E1 ARE DETERMINED AT THE OUTMOST EXTREMES OF THE PLASTIC BODY EXCLUSIVE OF MOLD FLASH, TIE BAR BURRS, GATE BURRS AND INTERLEAD FLASH, BUT INCLUDING ANY MISMATCH BETWEEN THE TOP AND BOTTOM OF THE PLASTIC BODY.
  - ⚠ DATUMS A, B AND D TO BE DETERMINED 0.18mm FROM THE LEAD TIP.
  - ⚠ TERMINAL NUMBERS ARE SHOWN FOR REFERENCE ONLY.

SYMBOL	MILLIMETERS			NOTE
	MINIMUM	NOMINAL	MAXIMUM	
A	1.50	1.50	1.60	
A1	0.60	—	0.10	
b	0.38	0.42	0.48	
b1	0.48	0.52	0.58	
b2	1.79	1.82	1.87	
c	0.40	0.42	0.46	
D	4.40	4.50	4.70	2,3
E	3.70	4.00	4.30	
E1	2.40	2.50	2.70	2,3
E2	0.80	1.00	1.20	
E3	0.40	0.50	0.60	
e	1.50 TYP.			
φ	4° TYP.			
R	0.15 TYP.			
R1	—	—	0.20	
SYMBOL	TOLERANCES OF FORM AND POSITION		NOTE	
aaa	0.15			
bbb	0.20			
ccc	0.10			
ddd	0.10			

### Suggested PCB Land Pattern and PAD Layout

**PCB Land Pattern**

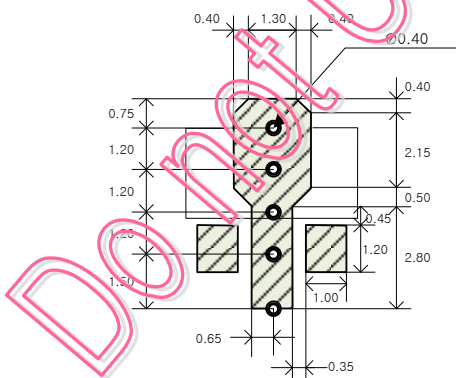

Note : All dimension \_ millimeters

PCB lay out \_ on BeRex website

**PCB Mounting**

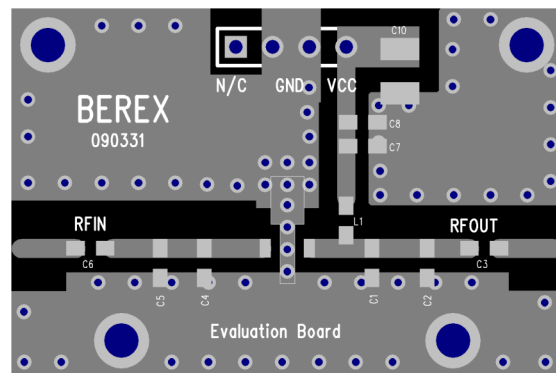

### Package Marking

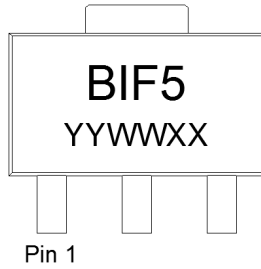

YY = Year, WW = Working Week,  
XX = Wafer No.

### Tape & Reel

SOT89

Packaging information:

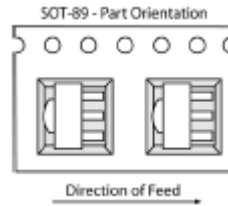

Tape Width (mm): 12  
Reel Size (inches): 7  
Device Cavity Pitch (mm): 8  
Devices Per Reel: 1000

### Lead plating finish

100% Tin Matte finish

(All BeRex products undergoes a 1 hour, 150 degree C, Anneal bake to eliminate thin whisker growth concerns.)

### MSL / ESD Rating

**ESD Rating:** Class 1C  
**Value:** Passes <2000V  
**Test:** Human Body Model (HBM)  
**Standard:** JEDEC Standard JESD22-A114

**MSL Rating:** Level 1 at +260°C convection reflow  
**Standard:** JEDEC Standard J-STD-020



Proper ESD procedures should be followed when handling this device.

**RoHS Compliance**

This part is compliant with Restrictions on the Use of Certain Hazardous Substances in Electrical and Electronic Equipment (RoHS) Directive 2011/65/EU as amended by Directive 2015/863/EU.

This product also is compliant with a concentration of the Substances of Very High Concern (SVHC) candidate list which are contained in a quantity of less than 0.1%(w/w) in each components of a product and/or its packaging placed on the European Community market by the BeRex and Suppliers.

**NATO CAGE code:**

2	N	9	6	F
---	---	---	---	---

Do not Use for New Design