

## Evaluation Kit Operation Manual

For DSA (Digital Step Attenuator) / DVGA (Digital Variable Gain Amplifier)

### 1. Introduction

This operation manual describes how to control the DSA(Digital Step Attenuator)/DVGA(Digital Variable Gain Amplifier) Evaluation board(EVB) using an Evaluation Control Interface board(EVCI). This Kit can be used to test and evaluate the various RF performance of the DSA/DVGA and is ideal for the functionality of the DSA and hardware development for RF system.

The DSA/DVGA Evaluation Board (EVB) is based on a combination of RF board and integrated interface board with FT232RL. and provides access to the USB ports as well as the SPI communication pins. This board was designed as a validation platform with maximum functionality. Where possible we've also designed for RF measurement environmental diversity but the primary goal of this system was control for DSA/DVGA.

### 2. Test Kit

The Kit should contain

1. BeRex DSA/DVGA RF Board (Evaluation Board – EVB)
2. Evaluation Control Interface board (EVCI)
3. USB Cable
4. GUI & USB Driver(Web download)

### Table of contents

1. Introduction .....	1
2. Test Kit.....	1
3. Evaluation Control Interface Board Overview.....	2
4. EVCI Board Functional Description.....	4
5. EVCI Board GUI.....	9

< Figure 1. The Evaluation Board Kit >

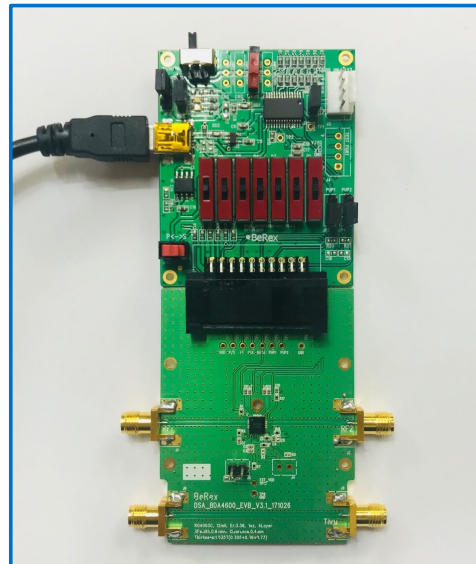

## 3. Evaluation Control Interface Board Overview

EVCI board allows the user to send SPI commands to the device under test by using a PC running the Windows™ operating system. The EVCI Board is responsible for interpreting commands from the USB and supplying the EVB with the appropriate control data on the 20-pin connector. And It supports direct parallel mode and serial mode at the same time, and provides the option of selecting External power and USB power according to user's environment.

< Figure 2. The EVCI Board >

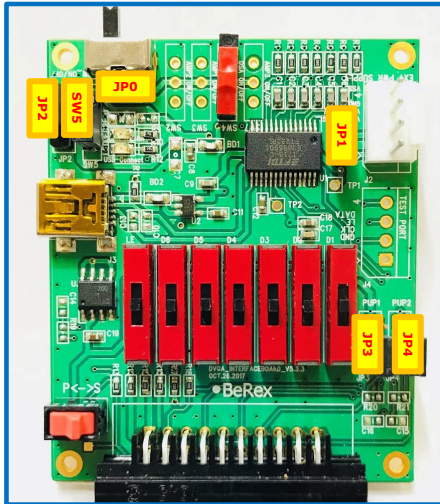

Jumpers provide flexibility of supplying voltage to the EVB either through USB or external power supply. Figure 2 shows the default orientation of the jumpers on EVCI.

Default Jumpers Setting.

1. Use VDD EXT 5V
2. Use VDD\_DIGITAL USB 5V
3. PUP1,2 set Reference Loss

Table 1. EVCI supported products and corresponding supply requirements

Part Number	Part Description	JP0	JP1	JP2	SW5	JP3	JP4	Interface Type
BVA303 /BVA303B	DVGA	Default jumper	Default jumper	Default High, as in Figure 3 (use EXT supply VDD)	Default Low, as in Figure 4 (use USB 5V)	Default Low, as in Figure 5 (Ref. Loss)	Default Low, as in Figure 5 (Ref. Loss)	Parallel, Serial (6bit)
BVA304 /BVA305B	DVGA	Default jumper	Default jumper	Default High, as in Figure 3 (use EXT supply VDD)	Default Low, as in Figure 4 (use USB 5V)	Default Low, as in Figure 5 (Ref. Loss)	Default Low, as in Figure 5 (Ref. Loss)	Parallel, Serial (6bit)
BVA305 /BVA305B	DVGA	Default jumper	Default jumper	Default High, as in Figure 3 (use EXT supply VDD)	Default Low, as in Figure 4 (use USB 5V)	Default Low, as in Figure 5 (Ref. Loss)	Default Low, as in Figure 5 (Ref. Loss)	Parallel, Serial (6bit)
BVA518	DVGA	Default jumper	Default jumper	Default High, as in Figure 3 (use EXT supply VDD)	Default Low, as in Figure 4 (use USB 5V)	Default Low, as in Figure 5 (Ref. Loss)	Default Low, as in Figure 5 (Ref. Loss)	Parallel, Serial (6bit)
BVA2140	DVGA	Default jumper	Default jumper	Default High, as in Figure 3 (use EXT supply VDD)	Default Low, as in Figure 4 (use USB 5V)	Default Low, as in Figure 5 (Ref. Loss)	Default Low, as in Figure 5 (Ref. Loss)	Serial (6bit)
BDA4600	DSA	Default jumper	Default jumper	Default High, as in Figure 3 (use EXT supply VDD)	Default Low, as in Figure 4 (use USB 5V)	Default Low, as in Figure 5 (Ref. Loss)	Default Low, as in Figure 5 (Ref. Loss)	Parallel, Serial (6bit)
BDA4601	DSA	Default jumper	Default jumper	Default High, as in Figure 3 (use EXT supply VDD)	Default Low, as in Figure 4 (use USB 5V)	Default Low, as in Figure 5 (Ref. Loss)	Default Low, as in Figure 5 (Ref. Loss)	Parallel, Serial (6bit)
BVA3143	DVGA	Default Open	Default Open	Default Open	Default Open	Default Open	Default Open	Serial (7bit)
BVA3144	DVGA	Default Open	Default Open	Default Open	Default Open	Default Open	Default Open	Serial (7bit)

Note1. BVA3143/BVA3144 are only operating in Serial interface mode. Then, JP0 ~ JP4 status don't care which connection is if it is just connected USB Cable to Mini USB Port. Therefore, Page4 to 8 can be ignored at the BVA3143/BVA3144.

## Overview

The Evaluation Control Interface (EVCI) Board is an evaluation platform for the FT232RL UART IC based interface board. Evaluation Board is support the USB2.0 interface and the Direct Parallel mode with SP3T switch manually. and supports the Functional option for USB power supply or user direct power supply.

< Figure 3. Evaluation Board Kit Assembly >

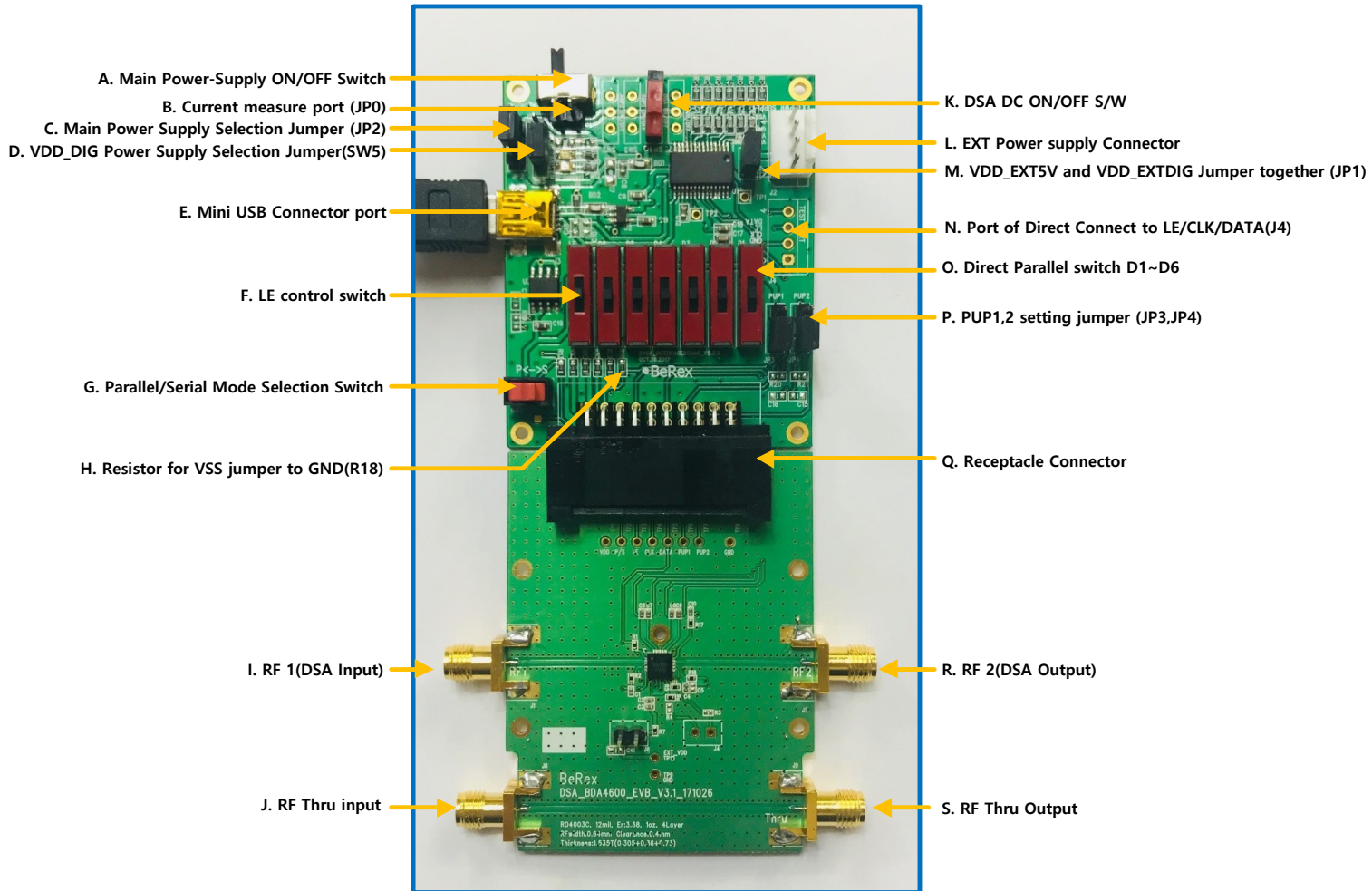

## DSA/DVGA EVB Power On Sequence

1. Confirm the jumper settings on the EVCI board are correct, as mentioned in earlier section
2. Connect EVCI and EVB. EVCI 20-pin Male Receptacle Connector mates with the EVB 20-pin connector
3. Connect the USB cable between the EVCI connector J3 and PC USB port. Once the USB cable is connected between the PC and EVCI, Red LED turns on the EVCI board
4. Connect and Supply VDD to the VDD\_EXT5V connector on the EVCI using external power supply, if required. Refer to Table 1. This supply is passed through the EVCI to the EVB.
5. EVCI Main PWR SW & DSA SW4 turns on
6. Start the EVCI GUI

## 4. EVCI Board Functional Description

### A. Main Power-Supply ON/OFF Switch

- Main Power-Supply ON/OFF Switch can be set to use main power supply setting ON/OFF

<Figure 4. Main Power set-up>

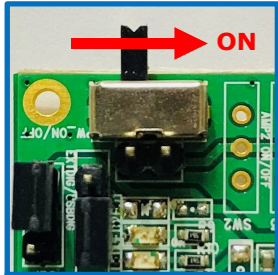

Main Power Switch direction  
 - RIGHT : ON  
 - LEFT : OFF

### B. Current Measure Port (JP0)

<Figure 5. Main Power set-up>



- This port may be used for one purposes

1. Use the Jumper, it is possible to send a power to the main chip by Interface board directly
2. No use Jumper and connect the cable to multimeter port, user can verify the current consumption

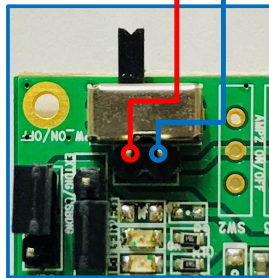

### C. Main Power Supply Selection Jumper (JP2)

- This jumper provide flexibility of supplying voltage to the interface board either through USB or external power supply (Default EXT5V)
- Jumper JP2\_H in the position shown below supplies the VDD\_EXT5V to "SW1" main power supply on/off switch directly
- Jumper JP2\_L in the position shown below provides 5V from the USB to "SW1" main power supply on/off switch directly (in this case, if you can't use external power supply, this mode will be supply the power to the device but it can cause voltage drop)

<Figure 6. Main Power Supply Selection Jumper>

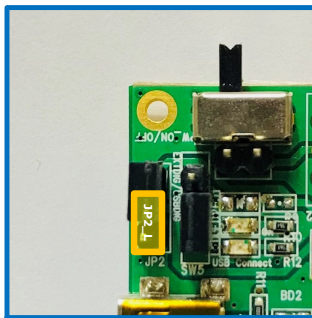
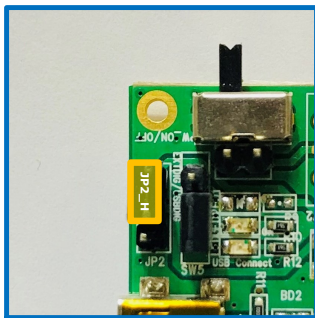

## 4. EVCI Board Functional Description

### D. DIG Power Supply Selection Jumper (SW5)

- This jumper control which one use digital power supply USB or EXT5V using interface board (Default: USB)
- SW5\_H(High) Position : Digital power supply set to use VDD\_EXTDIG power supply  
(in this case, there aren't any USB connection and user want to use parallel mode)
- SW5\_L(Lower) Position : Digital power supply set to use USB 5V power supply (in this case, connected USB and user control by GUI)

<Figure 7. DIG Power Supply selection Jumper>

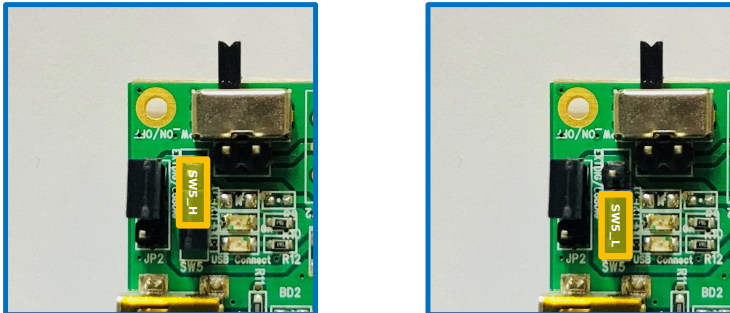

### E. Mini USB Connector port(J3)

<Figure 8. USB Port>

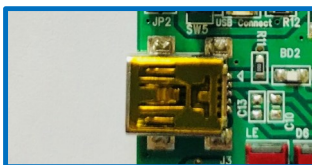

- Connect this connector of USB cable to Interface board. This supplies voltage to the Interface board and remote control

### G. Parallel/Serial mode selection(SW6, P/S)

<Figure 9. P/S Switch>

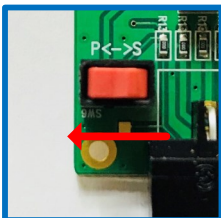

- This switch control to serial mode or parallel mode/Latched parallel mode
- Left direction (←) : Parallel mode and Latched Parallel mode.
- Right direction (→) : Serial mode

### H. Resistor for VSS jumper to GND(R18)

- This Resistor(0ohm) is shorted to GND to enable using the internal negative voltage generator.
- If you want to provide external negative power supply with -3.3V typical, R18 resistor must be removed and directly provide negative power supply from EXT power supply connector(J2, pin4)

### K. Separate Power supply ON/OFF Switch to DSA, AMP1, AMP2(SW2,SW3,SW4)

<Figure 10. DSA ON/OFF Switch>



- Each switch can be on/off the internal device independently of the chip
- SW4: DSA ON/OFF (upper direction is way to DSA DC Power ON)

## 4. EVCI Board Functional Description

### L. EXT Power supply Connector (J2)

- This connector is directly connected an main external power supply and independently it can be supplied to the external digital power (VDD\_EXTDIG) and VSS

<Figure 11. EXT Power supply >

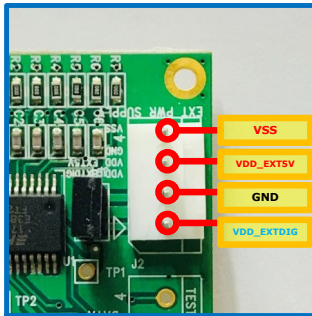

#### <Pin Description>

1. **VSS** : VSS is the external negative power supply with  $-3.3V$  typical. To simplify the test set-up, it can also be shorted to GND with Resistor R18 to enable using the internal negative voltage generator
2. **VDD\_EXT5V** : VDD\_EXT5 is the positive power supply  $5V$  typical
3. **GND**
4. **VDD\_EXTDIG** : VDD\_EXTDIG is the positive power supply for control signals with  $5V$  typical (but actual voltage supply to digital control is  $3V$ ), and it can be connected to VDD\_EXT5V with jumper on JP1 to simplify the test set-up

### M. VDD\_EXT5V and VDD\_EXTDIG Jumper together (JP1)

<Figure 12. EXT Power supply >

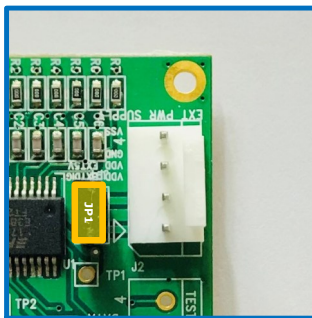

- This jumper can be provided with the main power supply(VDD\_EXT5V) to the digital power supply (VDD\_EXTDIG), when connected  
 notice: If this jumper is connected, it can result in an increase total consumption current. and suggest this jumper when you can not use USB connection. (ex. Only parallel mode)

### N. Port of Direct Connect to LE/CLK/DATA (J4)

- This port may be used for two purposes

1. By directly connecting the DATA/CLK/LE at this port, it is possible to send a control signal to the main chip by user' MCU
2. By directly connecting the DATA/CLK/LE at this port, user can verify the control signal sent to the main chip (ex: use oscilloscope)

## 4. EVCI Board Functional Description

### N. Direct Parallel Control Switch (LE, D1~D6)

- Set the D1~D6 and LE mechanical control switches on board to support Direct Parallel, Latched Parallel, or Serial mode
  - a. **Serial or Latched Parallel mode**(using GUI application software on PC)
    - Place D1~D6 and LE at the **middle position** to support Latched Parallel and Serial modes with GUI application software and proper position of P/S switch
  - b. **In Direct Parallel mode**(Using SP3T switch on Interface board without PC)
    - D1~D6 can be set to **"HIGH"** or **"LOW"** to manually program the attenuation state while LE is connected to **"HIGH"** without using the USB Interface and GUI application software

<Figure 13. Direct Parallel Control Switch>

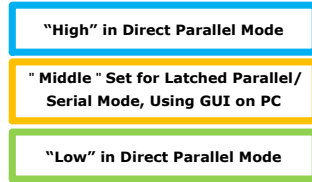
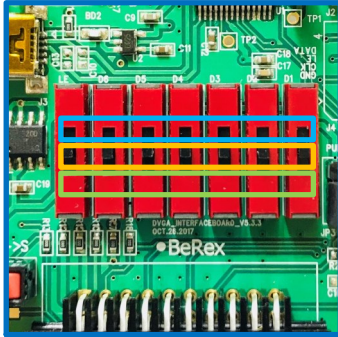

Table 2. SP3T Switch Descriptions for Parallel mode

D1	0.5dB
D2	1dB
D3	2dB
D4	4dB
D5	8dB
D6	16dB
LE	Latch enable

Table 3. Truth Table for the Parallel Control Word

LE	D6	D5	D4	D3	D2	D1	P/S	Attenuation State
High	Low	Low	Low	Low	Low	Low	Low (<-)	Reference Loss
High	Low	Low	Low	Low	Low	High	Low (<-)	0.5dB
High	Low	Low	Low	Low	High	Low	Low (<-)	1dB
High	Low	Low	Low	High	Low	Low	Low (<-)	2dB
High	Low	Low	High	Low	Low	Low	Low (<-)	4dB
High	Low	High	Low	Low	Low	Low	Low (<-)	8dB
High	High	Low	Low	Low	Low	Low	Low (<-)	16dB
High	High	High	High	High	High	High	Low (<-)	31.5dB

- Note: 1. Not all 64 possible combinations of C0.5-C16 are shown in table  
 2. BVA2140 do not support parallel mode, so DVGA interface board for BVA2140 is provided without programming switch(D1~D6,LE)

### O. Power-UP selector Jumper (JP3:PUP1, JP4:PUP2)

- PUP1,PUP2 selector jumper set to use PUP(Power UP) control setting. This Feature exists for both the Serial and Parallel modes of operation, and allows a known attenuation state to be established before an initial serial or parallel control word is provided (refer to page8 "HOW TO SET THE PUP"

<Figure 14. PUP set-up>

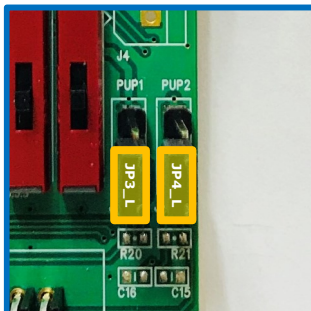

<PUP1:LOW, PUP2:LOW>



<PUP1:HIGH, PUP2:LOW>

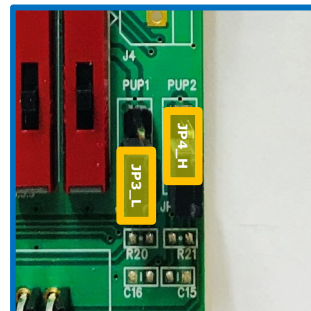

<PUP1:LOW, PUP1:HIGH>



<PUP1:HIGH PUP2:HIGH>

## 4. EVCI Board Functional Description

### HOW to set the PUP

1. Position the Parallel/Serial switch to Parallel mode
2. Set the "LE" Switch to "Low"
3. Set jumpers of PUP1 (JP3) and PUP2 (JP4) to be "HIGH" at upper position and "LOW" at down position as you need  
(refer to Table 4)

**Table 4. Parallel PUP Truth Table**

Attenuation state	P/S	LE	PUP1	PUP2
31.5 dB	LOW	LOW	HIGH	HIGH
16 dB	LOW	LOW	HIGH	LOW
8 dB	LOW	LOW	LOW	HIGH
Reference Loss	LOW	LOW	LOW	LOW
Defined by C0.5-C16	LOW	HIGH	Don't Care	Don't Care

4. Provide external power supply (turn on the Main Pwr SW or DSA on/off switch)



## 5. Evaluation Control Interface board(EVCI) GUI

The EVCI GUI application runs on a MS-Windows compatible PC. Once software is downloaded on to the PC, make sure to unzip the folder and one must have one files, another one folder (EVCI Gui and Driver folder) in the unzipped folder. The latest version of EVCI GUI software is available on TriQuint Website under specific product page.

### EVCI GUI Using Sequence A

#### (FTDI Driver installation)

1. Connect the USB Cable to EVCI
2. Confirm the pop-up in window as shown Figure15. (Found New Hardware Wizard or Installing device driver software window will pop up)
3. Pop-up window click
4. Select “No, not this time” and click on the “Next” button to continue (Figure 16)
5. Confirm the word “ USB SERIAL CONVERTER”
6. Select “Search for the best driver in these locations” and check box of “ include this location in the search”

Then click on the “Browse” button and browse to the location you unzipped the USB drivers to in the previous step (CDM v2.12.28 WHQL certified folder, <http://www.ftdichip.com/Drivers/VCP.htm>)

7. Select the file “**FTDIBUS.INF**”
8. Windows will install the first driver

< Figure 15. USB Serial Converter Driver Installation for windows 8 and 7 >

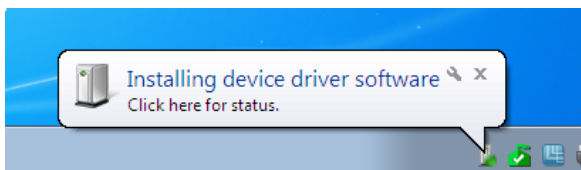

< Figure 16. USB Serial Converter Driver installation 1. >



< Figure 17. USB Serial Converter Driver installation 2. >



< Figure 18. USB Serial Converter Driver installation 3. >

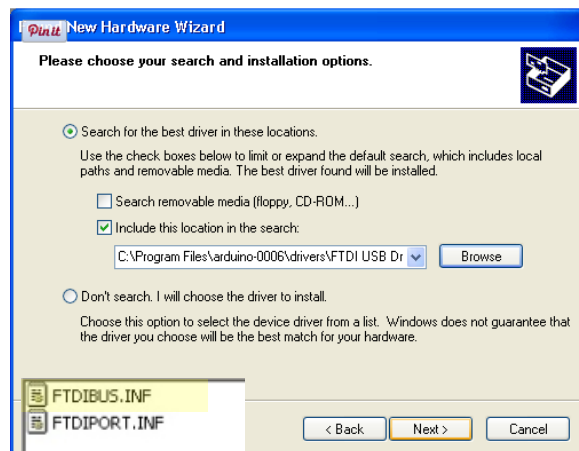

## 5. Evaluation Control Interface board(EVCI) GUI

### EVCI GUI Using Sequence B

(FTDI Driver installation)

1. The wizard will search for the driver and then tell you that a “USB Serial Port”
2. Pop-up window click
3. Confirm the word “ USB SERIAL PORT” and Click “Next”
4. Select “Search for the best driver in these locations” and check box of “ include this location in the search”
5. Then click on the “Browse” button and browse to the location you unzipped the USB drivers to in the previous step(CDM v2.12.28 WHQL certified folder)
6. Select the file “**FTDIPORT.INF**”
7. Windows will install the second driver. and then complete

< Figure 19. USB Serial Port Driver installation 1. >



< Figure 20. USB Serial Port Driver installation 2. >

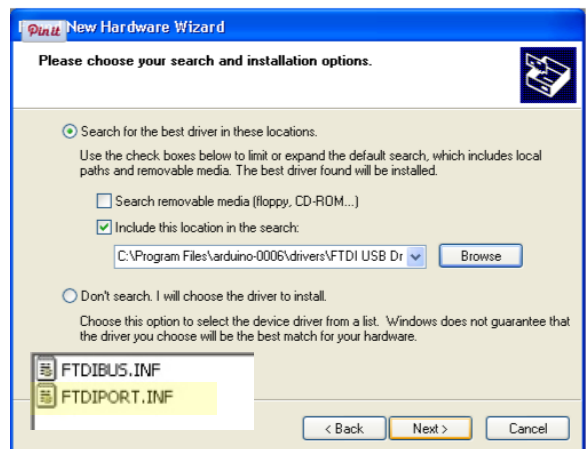

< Figure 21. USB Serial Port Driver installation 3. >



## 5. Evaluation Control Interface board(EVCI) GUI

### EVCI GUI Using Sequence C

(FTDI Driver installation)

1. Double Click “BeRex EVCI GUI V1” Icon
2. Running GUI and Control!

< Figure 22. USB Serial Port Driver installation 1. >

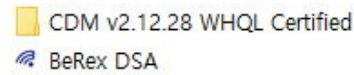

< Figure 23. BeRex EVCI GUI window >

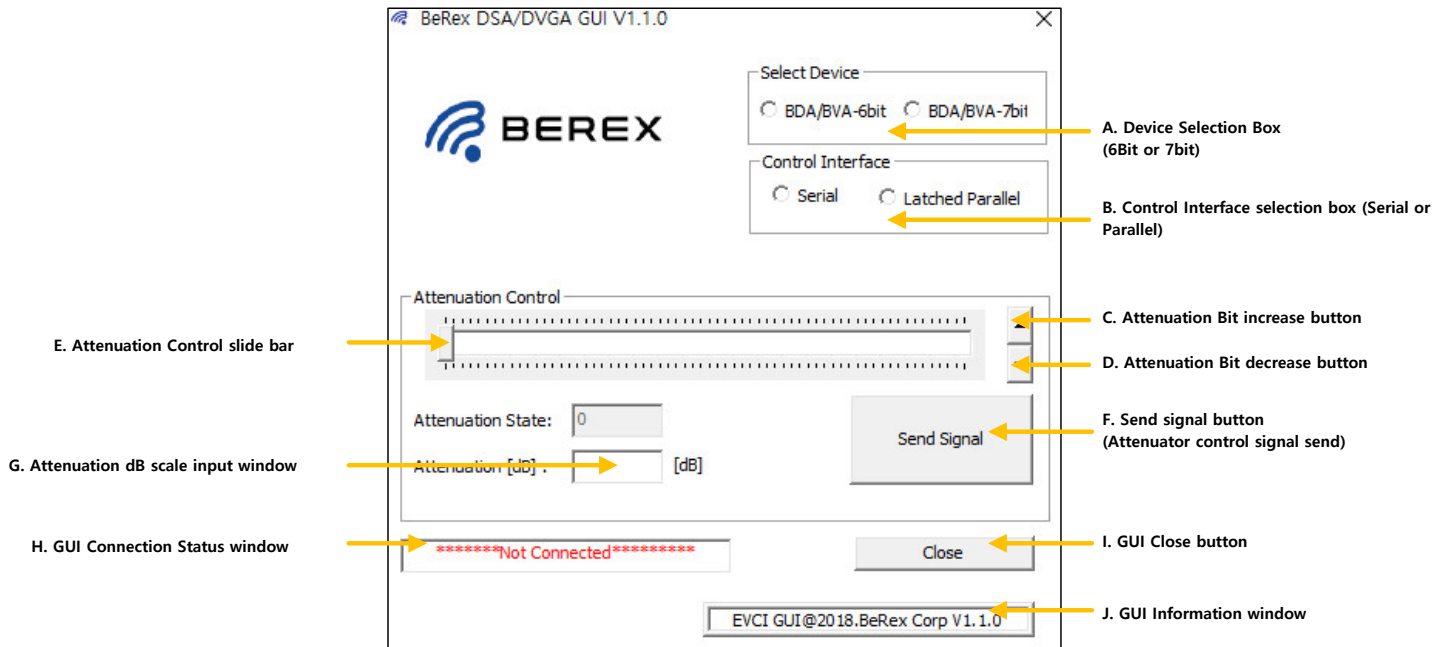

### EVCI GUI Using Sequence C

(GUI Control)

1. Select Device (Figure23 A)
2. Select control interface “Serial” or “Latched Parallel”
3. Setting the Attenuation Control through Attenuation control slide bar or Attenuation Bit increase/decrease button as you wish(Figure23 C,D,E)
4. Or input the number in Attenuation [dB] input window(Figure23 G)
5. Press button “Send signal” and then activate Attenuator in Device

Note: If the EVCI board is not connected when the application software is launched, the message “ **Not connected** ” will appear at the GUI Connection status window

### Contact Information

For technical questions and application information:

Email : [sales@berex.com](mailto:sales@berex.com)

Website : [www.berex.com](http://www.berex.com)