

RF MMIC Innovator

www.berex.com

[CLASSIFICATION] APPLICATION NOTE

[DATE] 2015. 01

[REVISION No.] REV.A

[MEASURING INSTRUMENTS]

- NA_AGILENT E5071B

- SA_AGILENT E4440A

- SG_AGILENT 4438C

- SG_IFR 3416

Wide Band Drive Amp BT013

Application Note



Contents

RF MMIC INNOVATOR WWW.BEREX.COM 1

1. 3500MHZ APPLICATION 3

 1.1 3500MHZ TEST RESULT(S-PARAMETER, OIP3, P1, NF,ACLR) 4

 1.2 3500MHZ LTE_20MHZ_ACLR TEST RESULT 5

2. 3700MHZ APPLICATION 6

 2.1 3700MHZ TEST RESULT(S-PARAMETER, OIP3, P1, NF,ACLR) 7

 2.2 3700MHZ LTE_20MHZ_ACLR TEST RESULT 8

1. BT013_ 3500MHz Application Note

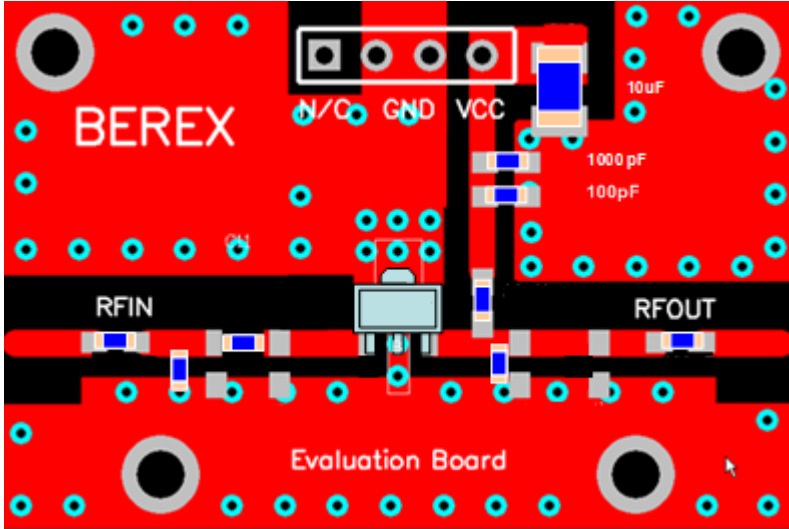

Ref. Des.	Description/ Part Number	Values	Vendor
C1	0603 CAP	100pF	Samsung
C2	0603 CAP	1nF	Samsung
C3	A3216 CAP	10uF	AVX
C4	0603 CAP	22pF	Samsung
C5	0603 CAP	22pF	Samsung
C6	0603 CAP	0.5pF	Samsung
C7	0603 CAP	0.5pF	Samsung
C8	0603 CAP	0.5pF	Samsung
L1	0603 IND	6.8nH	Ceratech
U1	SOT89 PKG	BT013	BEREX

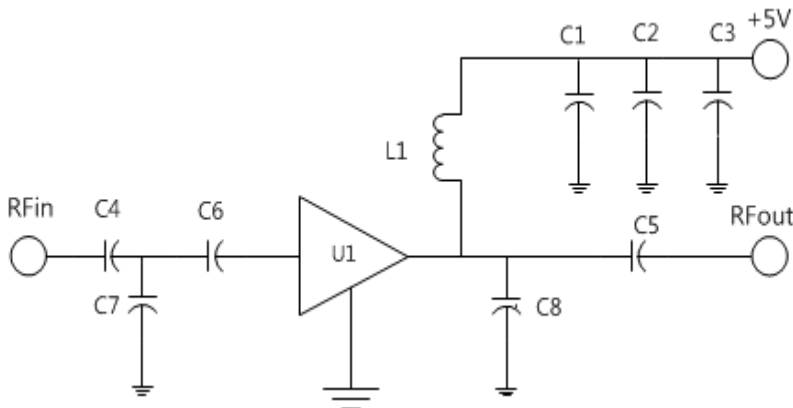

Note:

1. PCB: 31mil thick FR4

TITLE	
BT013 Evaluation Board	
(3500MHz)	
Drawing Number	Rev.
Date	Drawn By
FILE NAME	SHEET

1.1 BT013_3500MHz Test Result

SN	Freq [MHz]	Vcc [V]	Icc [mA]	Gain [dB]	OIP3 [dBm] ⁽¹⁾	P1dB [dBm]	IRL [dB]	ORL [dB]	NF [dB]
-	3400	5	134	10.7	39.6	26.0	-10.5	-23.1	6.5
-	3500	5	134	10.7	39.7	26.0	-15.3	-22.9	6.7
-	3600	5	134	10.2	40.1	25.9	-11.5	-16.5	6.7

(1) OIP3 was tested @Pout=13dBm/tone 1MHz offset

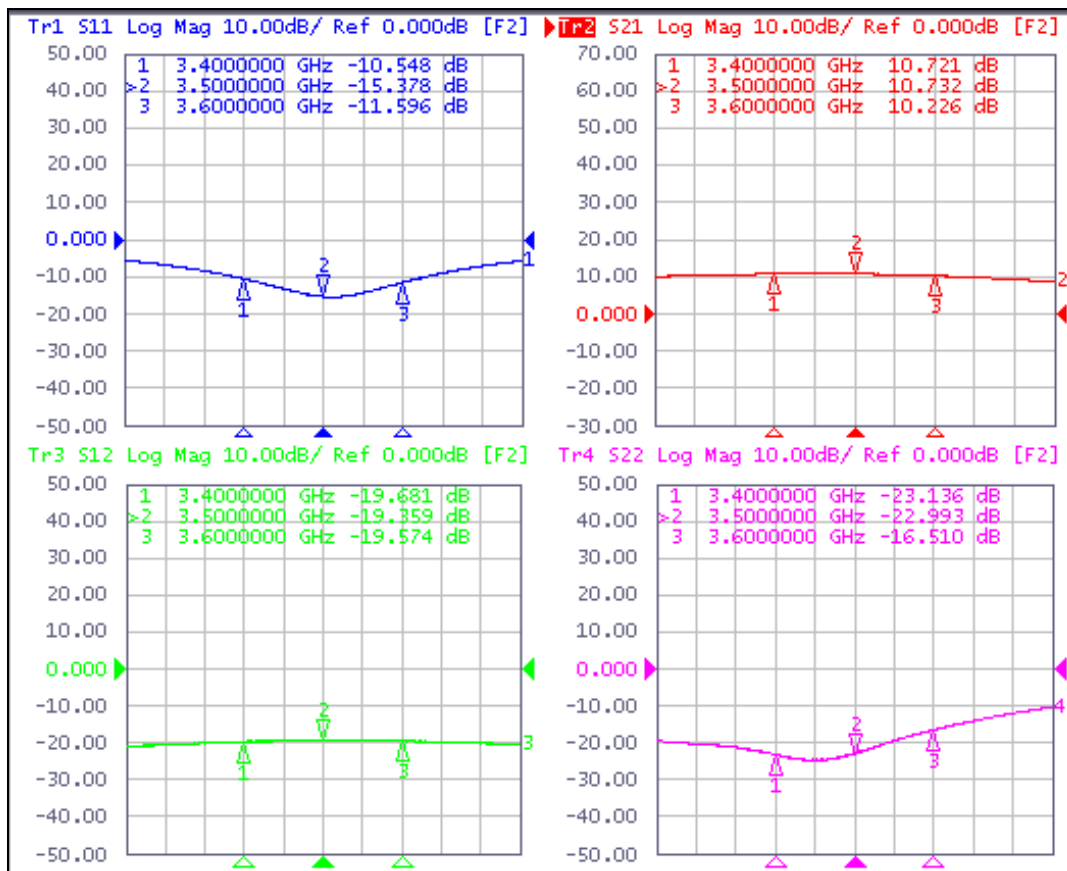

1.2 LTE_20MHz_ACLR Test Result

Out Power : 16 dBm

LTE_FDD_20MHz_TM 3.1_100% : 3500MHz -50dBc

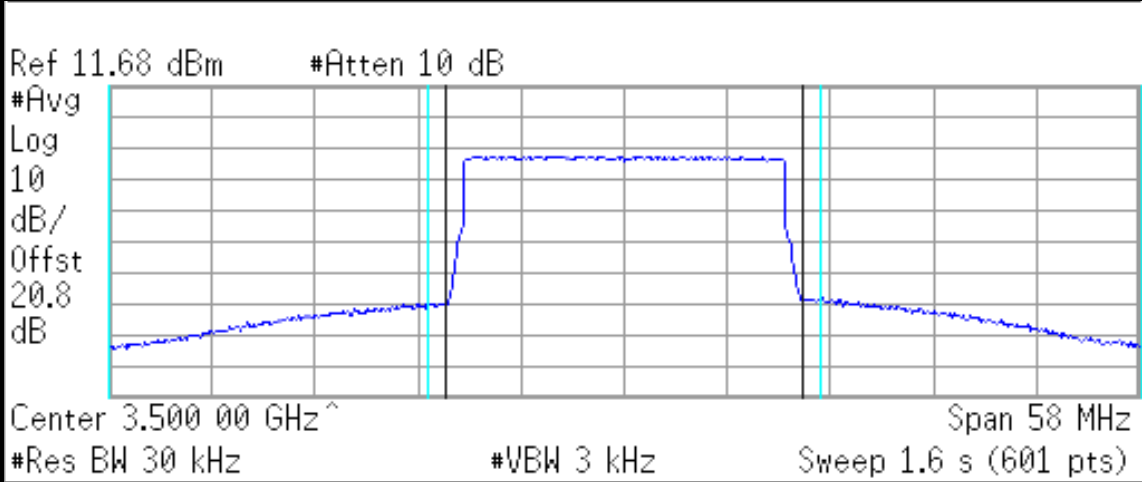

RMS Results		Freq	Offset	Ref BW	dBc	Lower	dBm	dBc	Upper	dBm
Carrier Power	16.02 dBm /	20.00 MHz	20.0000 MHz	18.00 MHz	-51.52	-35.50	-50.30	-34.29		

2. BT013_ 3700MHz Application Note

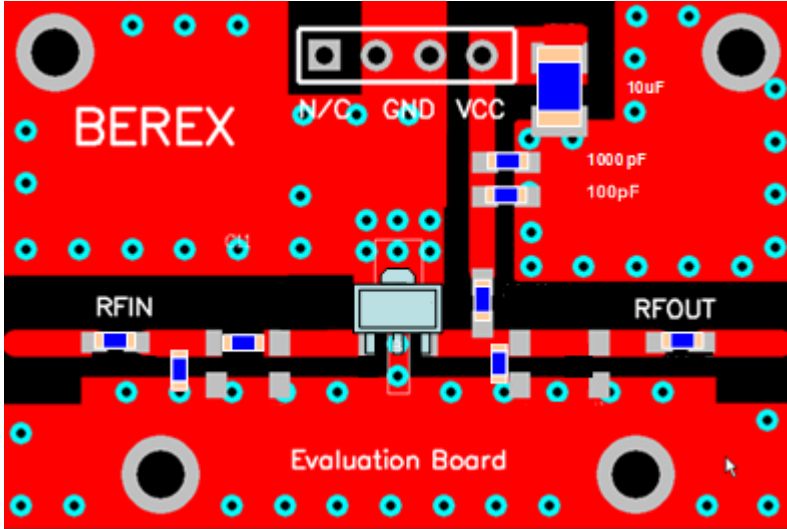

Ref. Des.	Description/ Part Number	Values	Vendor
C1	0603 CAP	100pF	Samsung
C2	0603 CAP	1nF	Samsung
C3	A3216 CAP	10uF	AVX
C4	0603 CAP	22pF	Samsung
C5	0603 CAP	22pF	Samsung
C6	0603 CAP	0.3pF	Samsung
C7	0603 CAP	0.3pF	Samsung
C8	0603 CAP	0.5pF	Samsung
L1	0603 IND	6.8nH	Ceratech
U1	SOT89 PKG	BT013	BEREX

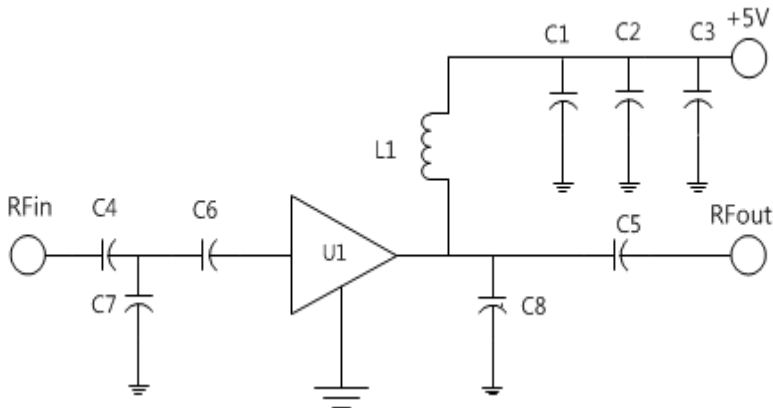

Note:

- 2. PCB: 31mil thick FR4

TITLE	
BT013 Evaluation Board	
(3700MHz)	
Drawing Number	Rev.
Date	Drawn By
FILE NAME	SHEET

2.1 BT013_3700MHz Test Result

SN	Freq [MHz]	Vcc [V]	Icc [mA]	Gain [dB]	OIP3 [dBm] ⁽¹⁾	P1dB [dBm]	IRL [dB]	ORL [dB]	NF [dB]
-	3600	5	132	10.1	40.1	25.7	-10.7	-24.0	6.7
-	3700	5	132	10.2	40.2	25.7	-22.9	-27.9	6.8
-	3800	5	132	9.8	40.1	25.4	-14.2	-17.9	7.0

(1) OIP3 was tested @Pout=13dBm/tone 1MHz offset

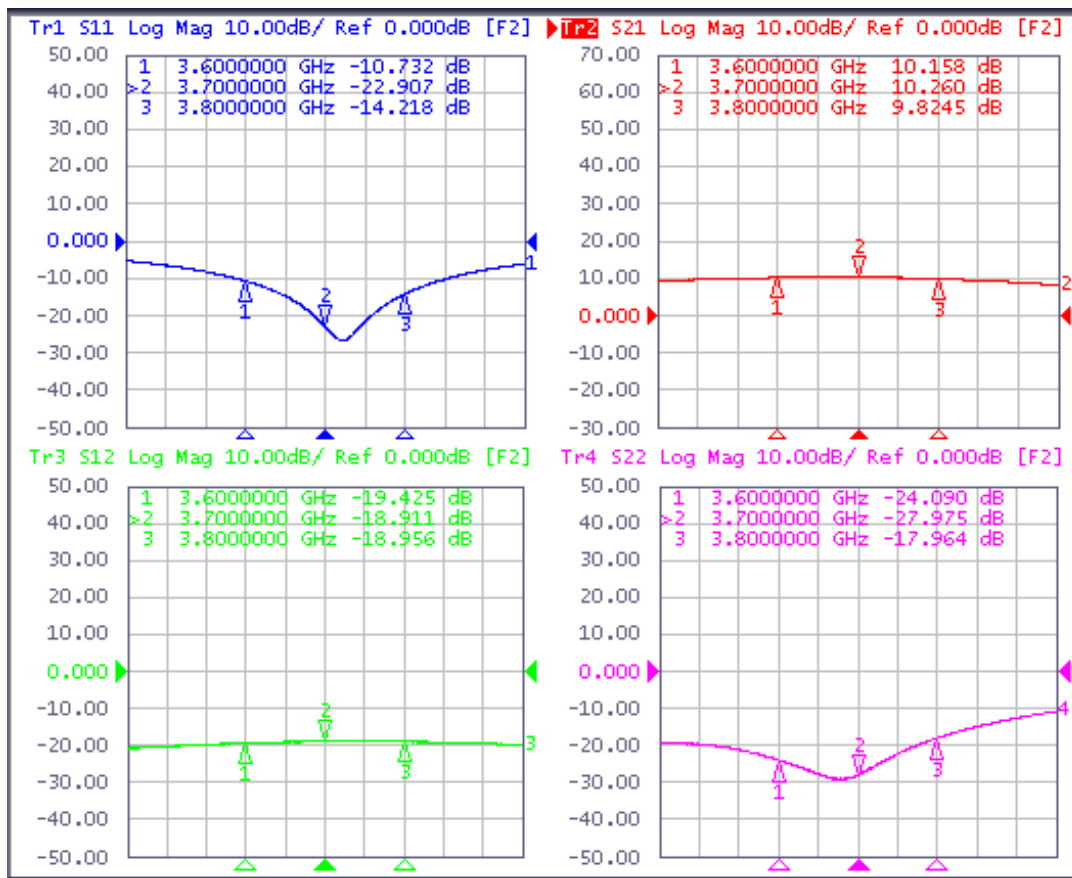

2.2 LTE_20MHz_ACLR Test Result

Out Power : 15.4 dBm

LTE_FDD_20MHz_TM 3.1_100% : 3700MHz -50dBc

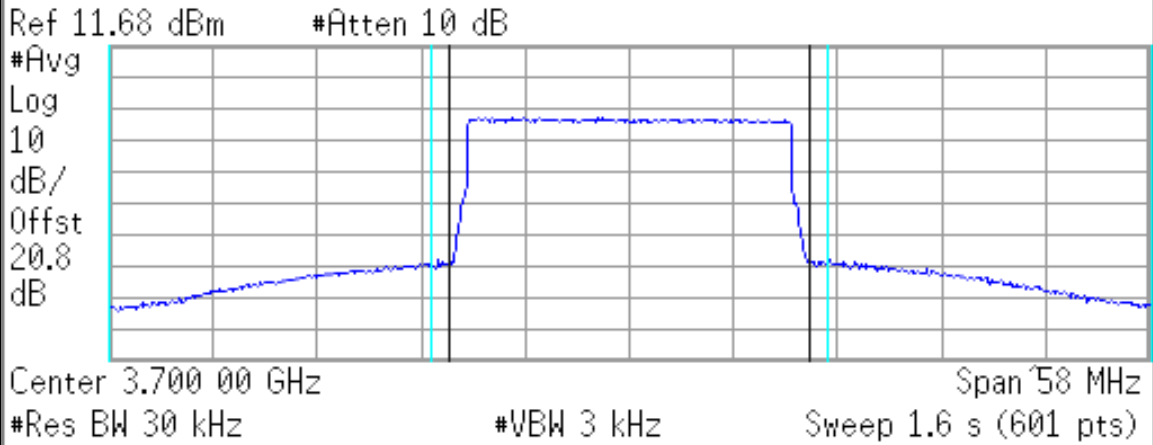

RMS Results	Freq Offset	Ref BW	dBc	Lower dBm	dBc	Upper dBm
Carrier Power	20.00 MHz	18.00 MHz	-50.22	-34.75	-49.62	-34.14
15.47 dBm /						
20.0000 MHz						